

ARTISAN®



**TORO 4500
Spare Parts
Manual**

CONTENT

1	PRECAUTIONS FOR USER-----	1
2	SPECIFICATION-----	2
3	PREPARATION FOR OPERATION-----	2
a.	Cleaing the machine-----	2
b.	Examination-----	2
c.	Lubrication-----	2
d.	Testing-----	3
4	HOW TO ATTACH A NEEDLE-----	3
5	WINDING OF BOBBIN THREAD-----	4
6	ADJUSTMENT OF THE BOBBIN WINDER-----	4
7	THREADING -----	5
8	REMOVING AND INSERTING THE BOBBIN-----	5
9	ADJUSTING THE THREAD TENSION-----	6
10	ADJUSTMENT OF PRESSER PRESSURE-----	6
11	ADJUSTMENT OF WALKING FOOT AND PRESSER FOOT-----	7
12	ADJUSTMENT OF STTICH LENGTH AND FORWARD/BACKWARD SEWING-----	7
13	FEED DOG HEIGHT-----	8
14	ADJUSTING THE HEIGHT OF THE NEEDLE BAR-----	8

1. PRECAUTIONS FOR USER

(1) Precautions for Safety

- ① When turning the power on, keep your hands and fingers away from the area around/under the needle and area around the pulley.
- ② The power must be turned off when the machine is not used, or when the operator leaves his/her seat.
- ③ The power must be turned off before installing or remove the "V" belt, adjusting the machine, or when replacing
- ④ Avoid placing fingers, hairs, bars etc. near the pulley, the "V" belt and the motor when the machine is in operation.
- ⑤ Do not put fingers under/around the needle or the pulley when the machine is in operation.

(2) Precautions before Operation

- ① Never operate the machine before it is lubricated fully.
- ② When a new sewing machine is first turned on, verify the rotational direction of the pulley with the power on.
(The pulley should rotate counterclockwise when viewed from the pulley)
- ③ Verify the voltage and phase (single or three) with those given on the motor nameplate.

(3) Precautions for Operating Conditions

- ① Avoid using the machine at abnormally high temperature (35°C or higher) or low temperature (5°C or lower).
- ② Avoid using the machine in dusty conditions.
- ③ Avoid using the machine in areas where there are too much electrical noise which resulted from the high-frequency weld and others.

2. SPECIFICATION

Max. sewing speed (r.p.m)	800 r.p.m	
Needle No.	DY×3 26#	
Needle bar stroke (mm)	56	
Thread take-up lever stroke (mm)	96	
Stitch length (mm)	0-15	
Presser-foot stroke	By hand (mm)	13
	By knee (mm)	20

3. PREPARATION FOR OPERATION

(1) Clean the machine

Before leaving the factory, the machine parts are coated with rust-preventive grease, which may be hardened and contaminated by dust during storage and shipment. This grease must be removed with gasoline.

(2) Examination

Though every machine is confirmed by strict inspection and test before leaving the factory, the machine parts may be loose or deformed after long distance transportation with jolt. A thorough examination must be performed after cleaning the machine. Turn the pulley to see if there is running obstruction, parts collision, uneven resistance or abnormal noise. If these exist, adjustment must be made accordingly before run-in operation

(3) Lubrication (Fig.1)

When a new sewing machine is used for the first time, or sewing machine left out of use for considerably long time is used again, replenish a suitable amount of oil to the portions indicated by arrow in below figure.

CAUTION: Please use white spindle oil.

Always keep the presser lifted before attempting a dry run.

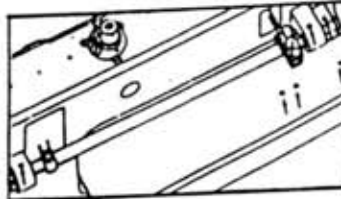
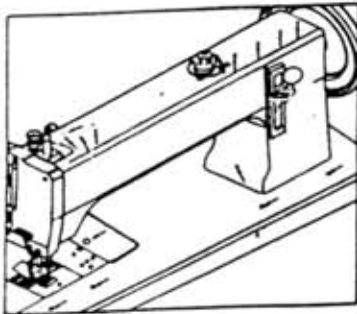

Fig.1

(4) Testing

In order to get the best working situation, run the sewing machine in a low speed for about 1 month after lubricated fully. Then increase the speed to the need one.

4. HOW TO ATTACH A NEEDLE (Fig.2)

CAUTION: Before using the following procedures, be sure to turn the power switch off.

The needle used by this sewing machine is DY×3 26#. During operation, proper needle can be chosen according to the sewing thread. (The sewing thread should be able to pass the pinhole.)

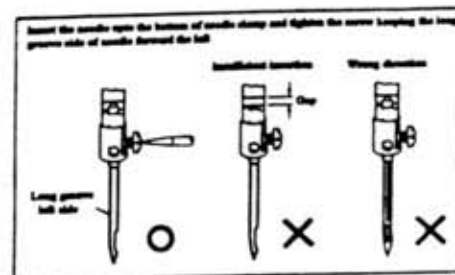

Fig.2

5..WINDING OF BOBBIN THREAD (Fig.3)

- (1) Push the bobbin ③ on the bobbin winder shaft as far as it will go.
- (2) Bring the thread forward toward the bobbin and wind from below in clockwise direction several times around the bobbin.
- (3) Push the level ⑤ toward other side so that the driving wheel and driven wheel will engage and then start the machine.
- (4) The driven wheel will automatically be free from the driving wheel and stop after the bobbin is filled with thread.

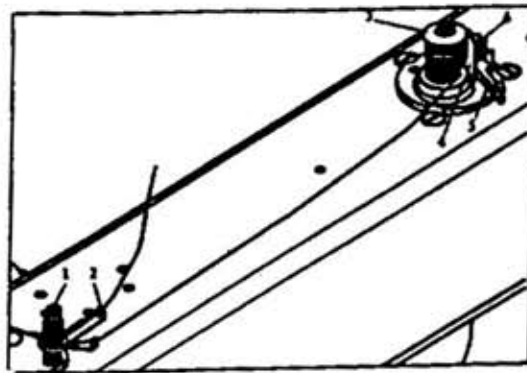

Fig.3

6. ADJUSTMENT OF THE BOBBIN WINDER (Fig.3)

- (1) In case of uneven winding
If the thread does not wind evenly on the bobbin, loosen the nut ① and move the bracket ② to the right or to the left as may be required, then tighten the nut.
- (2) Winding amount of thread
Adjusting ⑥ can increase or decrease the amount of thread wound on the bobbin.

(3) Winding strength

Strength of the winding can be adjusted with the nut ①.

7. THREADING (Fig.4)

Raise the needle bar to its highest position and route the upper thread in the order illustrated below.

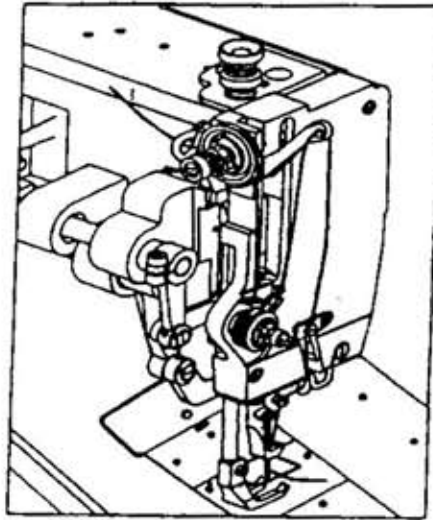

Fig.4

8. REMOVING AND INSERTING THE BOBBIN

- (1) Removing: Open the shuttle race cap and the bobbin holder, then take out the bobbin.
- (2) Installation: Put the bobbin in the rotary hook case, Permit about 5cm of bobbin thread to hang down freely. Install the bobbin in the bobbin case so that the thread wound direction is clockwise. Then close the rotary hook and the shuttle race cap.

9. ADJUSTMENT THE THREAD TENSION (Fig.5)

For ordinary stitching, the tension of the upper and the lower threads should be equal.

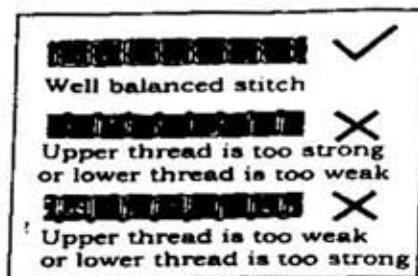

Fig.5

(1) Tension of the Upper thread

Before adjusting the tension of the upper thread, be sure that presser foot is let down. To adjust tension, turn serrated nut on tension device to the right (clockwise) will increase the thread tension, while turning it to the left (counter-clockwise) will decrease the tension.

(2) Tension of the lower thread

The lower thread tension is controlled by the larger screw near the end of the spring at the outside of the bobbin case. Turning this screw to the right (clockwise) will increase the thread tension, while turning it to the left (counter-clockwise) will decrease the tension.

10. ADJUSTMENT OF PRESSER PRESSURE (Fig.6)

- (1) Pressure should be adjusted according to the material to be sewn.
- (2) Pressure on both the walking foot and the presser foot can be adjusted.(The adjusting screw has been set before shipment.)
- (3) Sewing pressure should be adjusted to the minimum required strength.

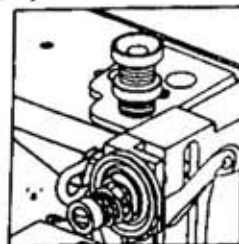

11 ADJUSTMENT OF WALKING FOOT AND PRESSER FOOT

(Fig.7)

(1). The alternating movement on the walking foot and presser foot can be adjusted by changing the position relations of the parts of the presser foot lifting mechanism.

(2) Changing the position relation of the connecting link 2 and the crank 3 can complete the adjustment.

(3) Adjustment should be changed according to the thickness of the material to be sewn.

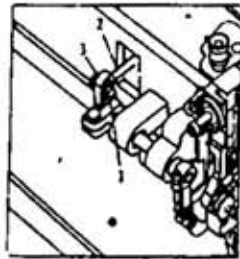

Fig.7

12. ADJUSTMENT OF STITCH LENGTH AND FORWARD/BACKWARD SEWING (Fig.8)

(1) Adjusting the stitch length adjusting bolt can change the stitch length.

(2) Stitch length can be adjusted between 0-11 mm.

(4) Setting the stitch length adjusting bolt above "0" can backstitch.

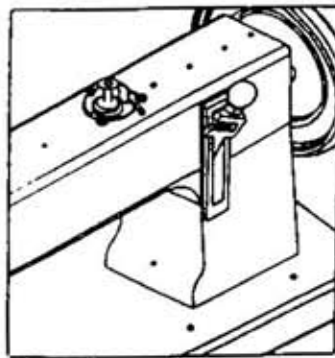

Fig.8

13. FEED DOG HEIGHT (Fig.9)

The feed dog should be 1.5 mm higher than the vertex of the needle plate. Adjustment of the feed dog height can be done as follows:

- (1) Turn the machine pulley so as to raise the feed dog to its highest point.
- (2) Loosen the screw of the feed dog and adjust the height by raising or lowering it. Then tighten the screw.

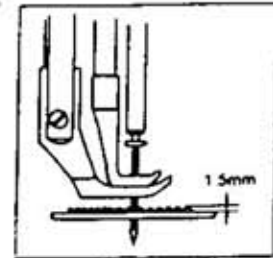

Fig.9

14. ADJUSTING THE HEIGHT OF THE NEEDLE BAR (Fig.10)

When the needle bar is at its highest point, normally the measurement between the highest point of the needle plate and the needlepoint is 28 mm. When this distance need to be adjusted, the steps is as follows:

- (1) Take down the face plate, adjust the needle bar to its highest position.
- (2) Loosen the screw of needle bar connecting stud screw.
- (3) Adjust the needle bar to the right position.
- (4) Tighten the screw.

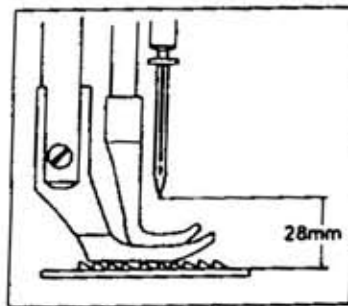
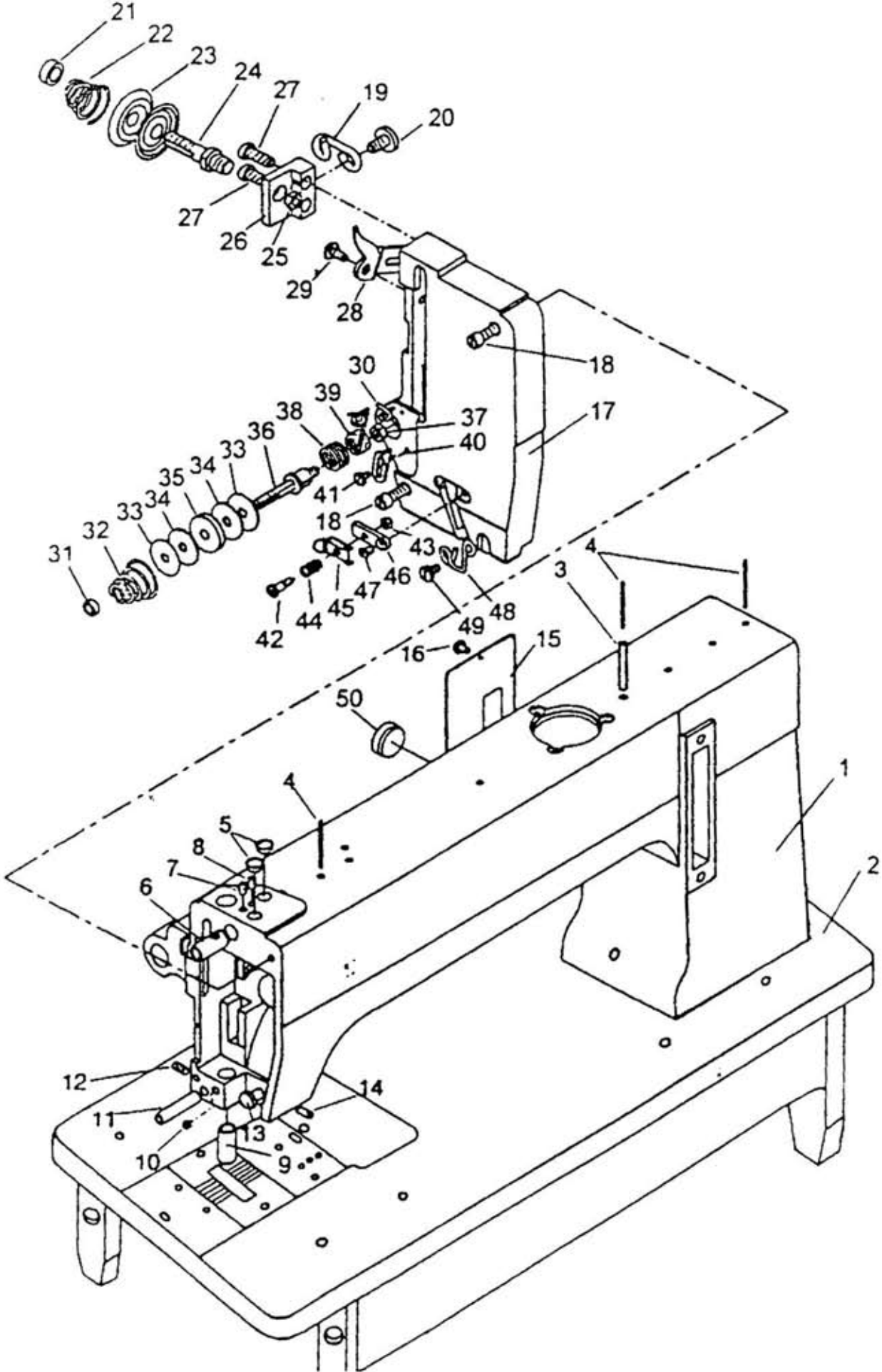

Fig.10

A: BODY AND ITS ACCESSORIES



A: BODY AND ITS ACCESSORIES

No.	Ref. No.	Description	Pcs.
A1	H9601001	Arm	1
A2	H9601002	Bed	1
A3	H9601003	Oil pipe	1
A4	H9601004	Oil wick	3
A5	H9601005	Rubber plug	2
A6	H9601006	Needle bar guide bracket stud bushing	1
A7	H9601007	Set Screw	1
A8	H9601008	Set Screw	1
A9	H9601009	Presser bar bushing	1
A10	H9601010	Set Screw	1
A11	H9601011	Pin	1
A12	H9601012	Set Screw	1
A13	H9601013	Mandril of needle bar guide bracket	1
A14	H9601014	Set Screw	1
A15	H9601015	Arm side cover	1
A16	H9601016	Screw	1
A17	H9601017	Face plate	1
A18	H9601018	Screw	2
A19	H9601019	Thread guide	1
A20	H9601020	Screw	1
A21	H9601021	Nut	1
A22	H9601022	Tension spring	1
A23	H9601023	Tension disc	2
A24	H9601024	Tension screw stud	1
A25	H9601025	Tension nut	1
A26	H9601026	Thread tension regulator complete base	1
A27	H9601027	Screw	2
A28	H9601028	Tension releasing disc	1
A29	H9601029	Screw	1
A30	H9601030	Thread guide	1
A31	H9601031	Tension nut	1
A32	H9601032	Tension spring	1
A33	H9601033	Washer	2
A34	H9601034	Felt	2
A35	H9601035	Damping plate	1
A36	H9601036	Tension screw stud	1
A37	H9601037	Nut	1
A38	H9601038	Thread take-up spring	1
A39	H9601039	Spring	1
A40	H9601040	Thread take-up spring guide plate	1
A41	H9601041	Screw	1

A42	H9601042	Screw	1
A43	H9601043	Nut	1
A44	H9601044	Tension spring	1
A45	H9601045	Tension disc	1
A46	H9601046	Thread tension regulator complete base	1
A47	H9601047	Screw	1
A48	H9601048	Thread guide	1
A49	H9601049	Screw	1
A50	H9601050	Rubber plug	1

B: NEEDLE BAR AND THREAD TAKE-UP MECHANISM

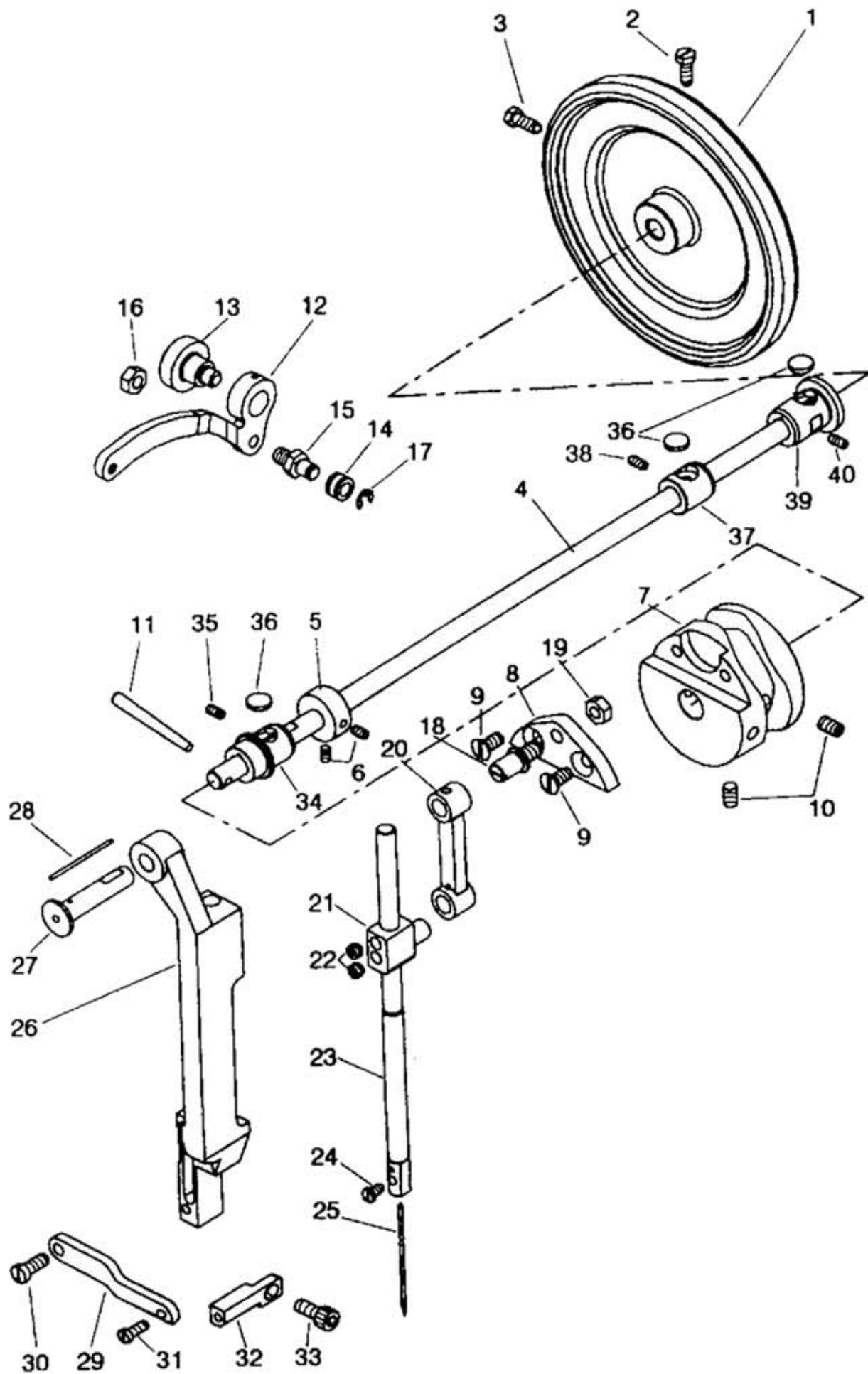

B: NEEDLE BAR AND THREAD TAKE-UP MECHANISM

No.	Ref. No.	Description	Pcs.
B1	H9602001	Pulley	1
B2	H9602002	Screw	1
B3	H9602003	Screw	1
B4	H9602004	Arm shaft	1
B5	H9602005	Collar	1
B6	H9602006	Set Screw	2
B7	H9602007	Thread take-up cam	1
B8	H9602008	Needle bar connecting base link screw	1
B9	H9602009	Screw	2
B10	H9602010	Set Screw	2
B11	H9602011	Pin	1
B12	H9602012	Thread take-up lever	1
B13	H9602013	Screw	1
B14	H9602014	Roller	1
B15	H9602015	Roller pin	1
B16	H9602016	Nut	1
B17	H9602017	Retaining ring-E type	1
B18	H9602018	Needle bar connecting link screw	1
B19	H9602019	Nut	1
B20	H9602020	Needle bar connecting link	1
B21	H9602021	Needle bar connecting stud	1
B22	H9602022	Set Screw	2
B23	H9602023	Needle bar	1
B24	H9602024	Screw	1
B25	H9602025	Needle	1
B26	H9602026	Needle bar guide bracket	1
B27	H9602027	Needle bar guide bracket pin	1
B28	H9602028	Oil wick	1
B29	H9602029	Needle bar guide bracket plate	1
B30	H9602030	Screw	1
B31	H9602031	Screw	1
B32	H9602032	Needle bar guide bracket plate base	1
B33	H9602033	Screw	1
B34	H9602034	Bushing	1
B35	H9602035	Set Screw	1
B36	H9602036	Felt	3
B37	H9602037	Bushing	1
B38	H9602038	Set Screw	1
B39	H9602039	Bushing	1
B40	H9602040	Set Screw	1

C: LOWER SHAFT MECHANISM

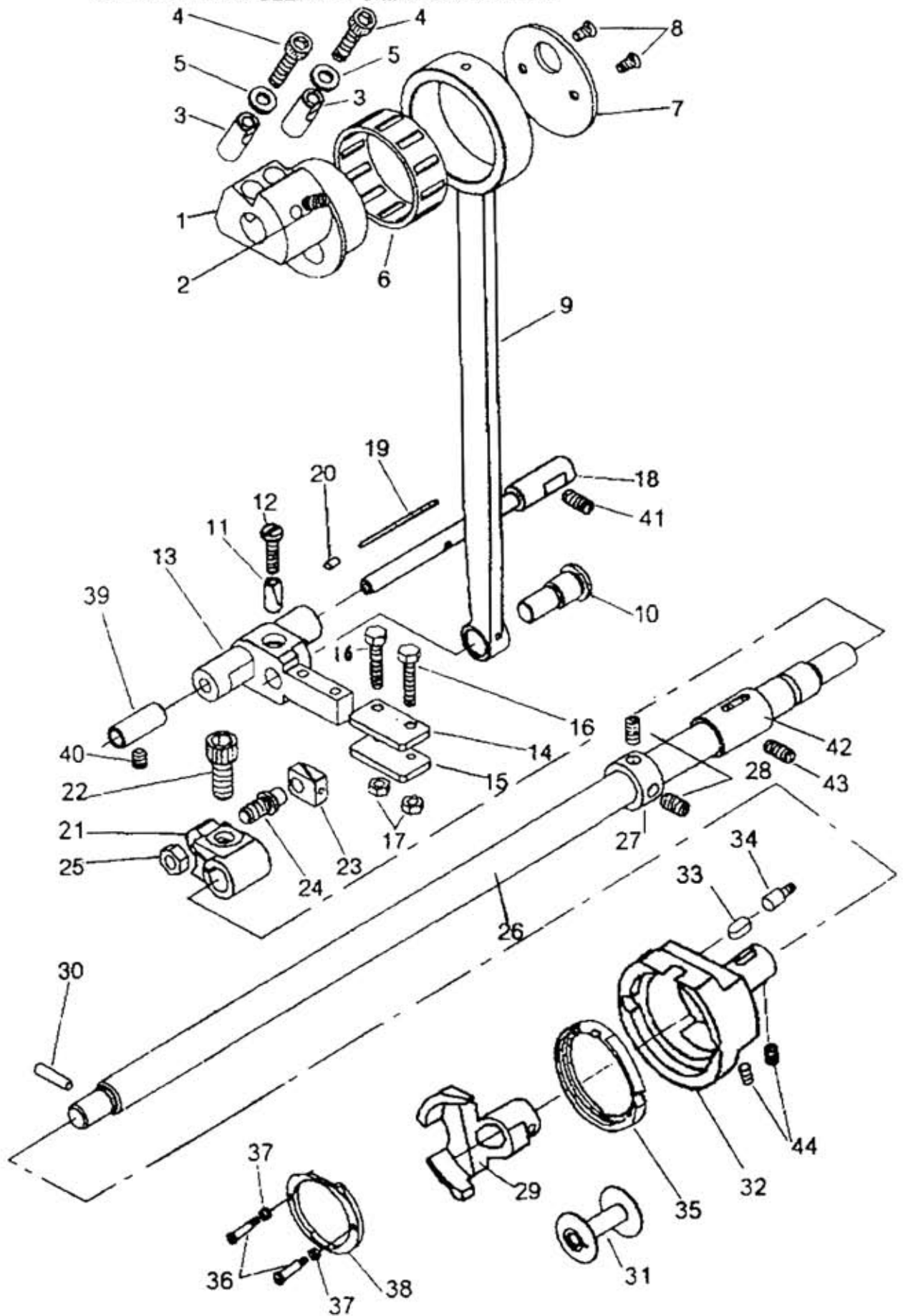

C: LOWER SHAFT MECHANISM

No.	Ref. No.	Description	Pcs.
C1	H9603001	Eccentric	1
C2	H9603002	Set screw	1
C3	H9603003	Pin	2
C4	H9603004	Screw	2
C5	H9603005	Washer	2
C6	H9603006	Bearing	1
C7	H9603007	Eccentric cover	1
C8	H9603008	Screw	2
C9	H9603009	Crank connecting rod	1
C10	H9603010	Crank connecting rod pin	1
C11	H9603011	Pin	1
C12	H9603012	Screw	1
C13	H9603013	Shuttle shaft	1
C14	H9603014	Plate	1
C15	H9603015	Plate	1
C16	H9603016	Screw	2
C17	H9603017	Nut	2
C18	H9603018	Inside shaft	1
C19	H9603019	Oil wich	1
C20	H9603020	Rivet	1
C21	H9603021	Lower shaft crank	1
C22	H9603022	Screw	1
C23	H9603023	Shuttle shaft slide block	1
C24	H9603024	Screw	1
C25	H9603025	Nut	1
C26	H9603026	Lower shaft	1
C27	H9603027	Collar	1
C28	H9603028	Set screw	2
C29	H9603029	Shuttle driver	1
C30	H9603030	Pin	1
C31	H9603031	Bobbin	1
C32	H9603032	Shuttle hook base	1
C33	H9603033	Felt	1
C34	H9603034	Screw	1
C35	H9603035	Shuttle race body	1
C36	H9603036	Screw	2
C37	H9603037	Spring	2
C38	H9603038	Shuttle race cap	1
C39	H9603039	Bushing	1
C40	H9603040	Set screw	1
C41	H9603041	Set screw	1

D: FEEDING MECHANISM

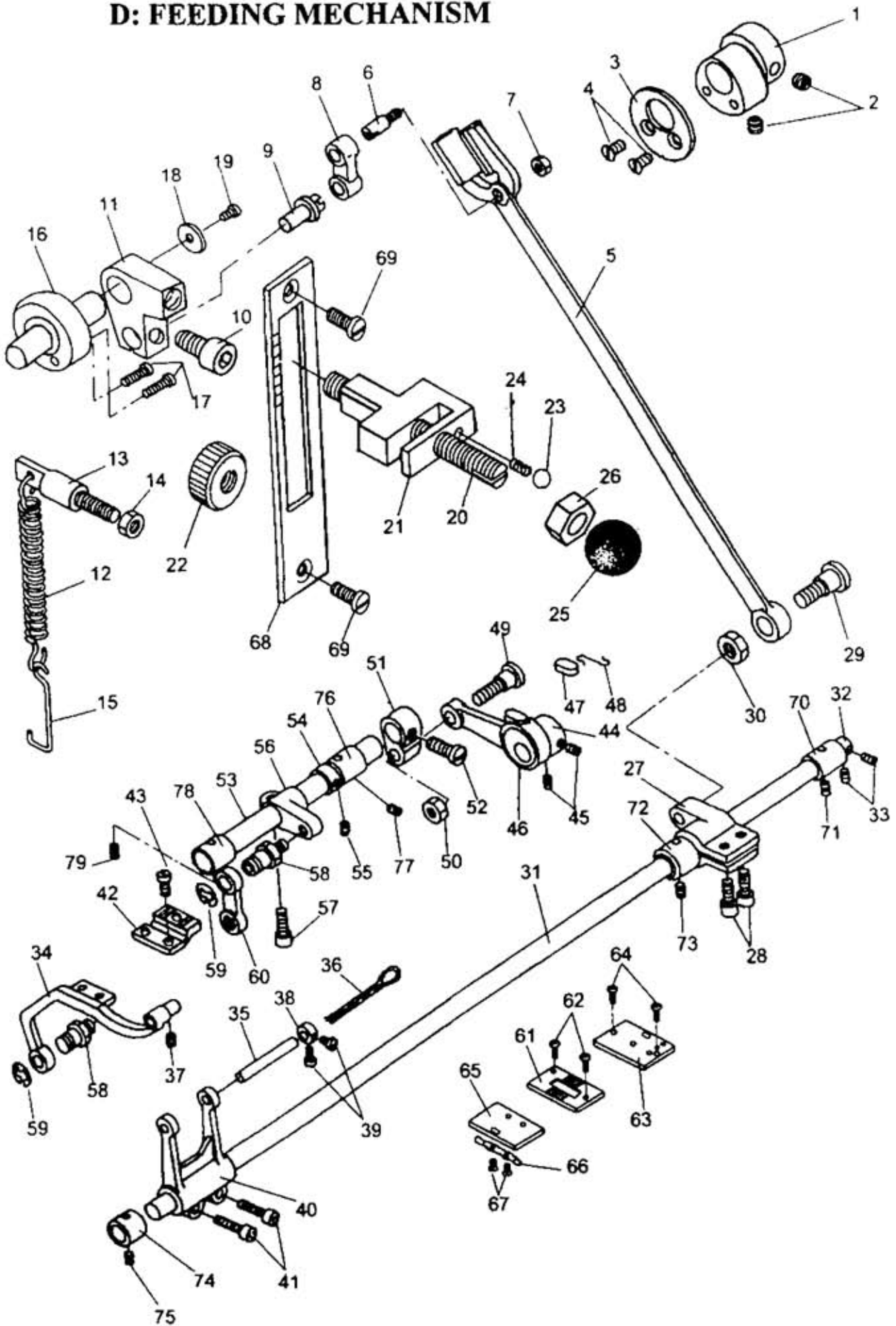

D: FEEDING MECHANISM

No.	Ref. No.	Description	Pcs.
D1	H9604001	Feed cam	1
D2	H9604002	Set screw	2
D3	H9604003	Feed cam cover	1
D4	H9604004	Screw	2
D5	H9604005	Feed forked connection	1
D6	H9604006	Feed forked connection crank pin	1
D7	H9604007	Nut	1
D8	H9604008	Stitch length connecting link	1
D9	H9604009	Stitch length connecting link crank pin	1
D10	H9604010	Screw	1
D11	H9604011	Stitch length adjusting pin	1
D12	H9604012	Spring	1
D13	H9604013	Screw bar	1
D14	H9604014	Nut	1
D15	H9604015	Hook	1
D16	H9604016	Damping plate	1
D17	H9604017	Screw	2
D18	H9604018	Spacer	1
D19	H9604019	Screw	1
D20	H9604020	Stitch length adjusting bolt	1
D21	H9604021	Stitch length limited plate	1
D22	H9604022	Nut	1
D23	H9604023	Metal ball	1
D24	H9604024	Spring	1
D25	H9604025	Plastic ball	1
D26	H9604026	Nut	1
D27	H9604027	Feed driving rock shaft crank	1
D28	H9604028	Screw	2
D29	H9604029	Screw	1
D30	H9604030	Nut	1
D31	H9604031	Collar	1
D32	H9604032	Set screw	1
D33	H9604033	Crank pin	2
D34	H9604034	Feed dog base	1
D35	H9604035	Crank shaft	1
D36	H9604036	Oil wick	1
D37	H9604037	Screw	1
D38	H9604038	Collar	1
D39	H9604039	Screw	2
D40	H9604040	Crank	1
D41	H9604041	Screw	2

D42	H9604042	Feed dog	1
D43	H9604043	Screw	2
D44	H9604044	Feed lifting eccentric	1
D45	H9604045	Screw	2
D46	H9604046	Feed lifting connection	1
D47	H9604047	Felt	1
D48	H9604048	Spring	1
D49	H9604049	Screw	1
D50	H9604050	Nut	1
D51	H9604051	Crank	1
D52	H9604052	Screw	1
D53	H9604053	Feed lifting shaft	1
D54	H9604054	Collar	1
D55	H9604055	Screw	2
D56	H9604056	Crank	1
D57	H9604057	Screw	1
D58	H9604058	Hinge bar	2
D59	H9604059	Washer	2
D60	H9604060	Link	1
D61	H9604061	Needle plate	1
D62	H9604062	Screw	2
D63	H9604063	Fitting plate	1
D64	H9604064	Screw	2
D65	H9604065	Slide plate	1
D66	H9604066	Spring	1
D67	H9604067	Screw	2
D68	H9604068	Stitch length indicating plate	1
D69	H9604069	Screw	2
D70	H9604070	Bushing	1
D71	H9604071	Set screw	1
D72	H9604072	Bushing	1
D73	H9604073	Set screw	1
D74	H9604074	Bushing	1
D75	H9604075	Set screw	1
D76	H9604076	Bushing	1
D77	H9604077	Set screw	1
D78	H9604078	Bushing	1
D79	H9604079	Set screw	1

E: PRESSER FOOT MECHANISM

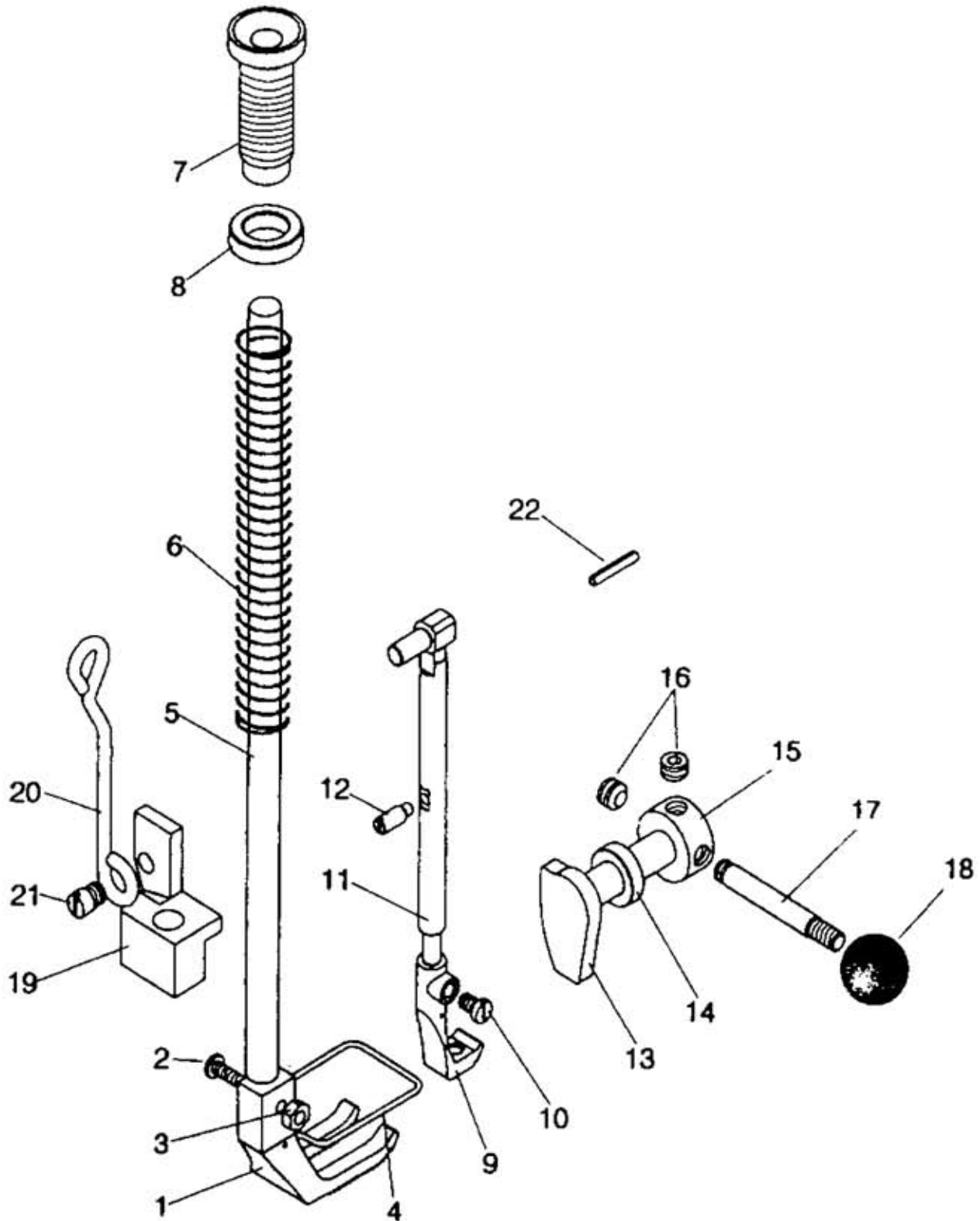

E: PRESSER FOOT MECHANISM

No.	Ref. No.	Description	Pcs.
E1	H9605001	Presser foot	1
E2	H9605002	Screw	1
E3	H9605003	Nut	1
E4	H9605004	Finger guard	1
E5	H9605005	Presser bar	1
E6	H9605006	Presser bar spring	1
E7	H9605007	Thumb screw	1
E8	H9605008	Nut	1
E9	H9605009	Walking foot	1
E10	H9605010	Screw	1
E11	H9605011	Presser bar	1
E12	H9605012	Screw	1
E13	H9605013	Presser bar lifting shaft	1
E14	H9605014	Washer	1
E15	H9605015	Collar	1
E16	H9605016	Set screw	2
E17	H9605017	Bolt	1
E18	H9605018	Plastic ball	1
E19	H9605019	Presser bar guide bracket	1
E20	H9605020	Connecting rod	1
E21	H9605021	Screw	1
E22	H9605022	Pin	1

F: PRESSER FOOT LIFTING SHAFT MECHANISM

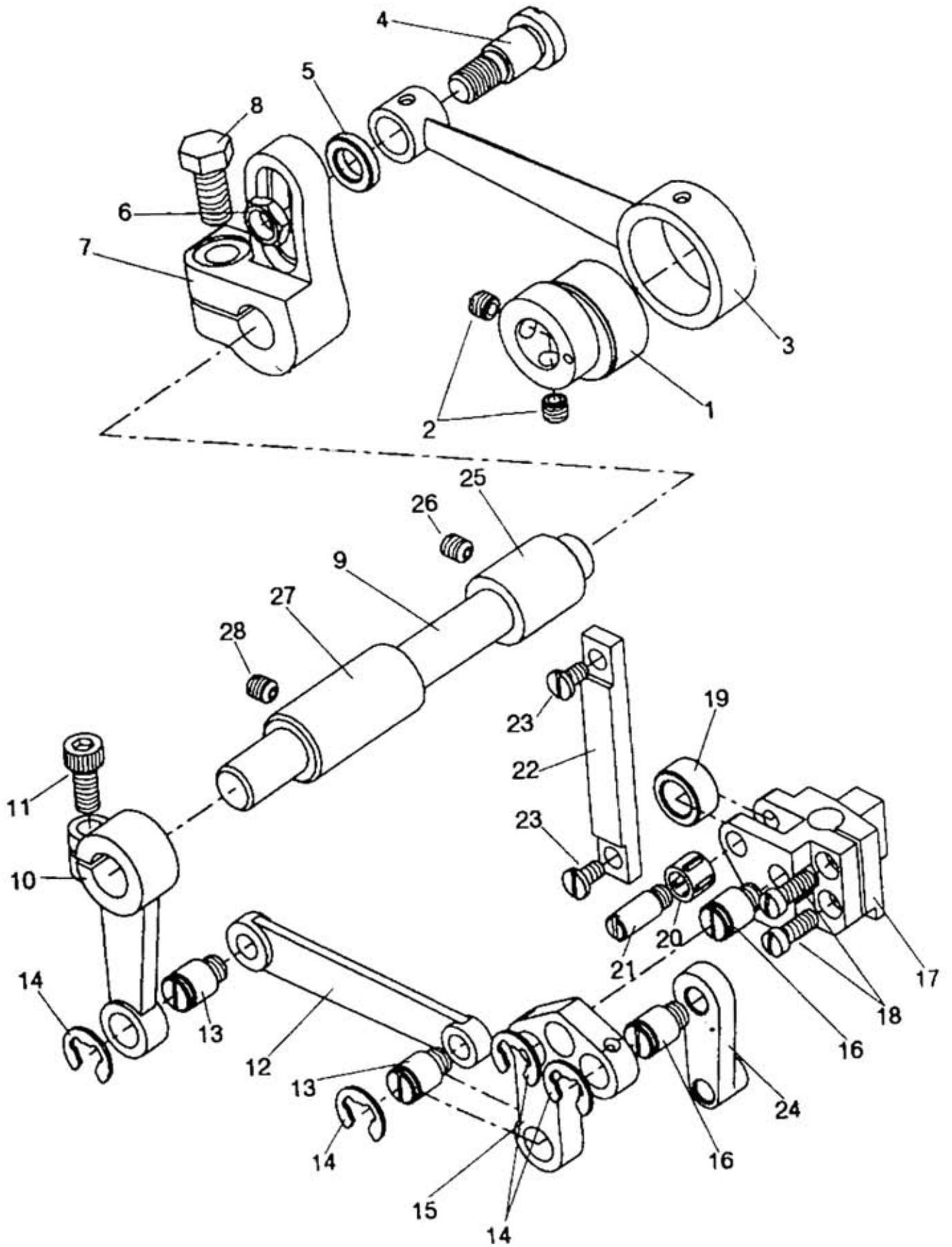

F: PRESSER FOOT LIFTING SHAFT MECHANISM

No.	Ref. No.	Description	Pcs.
F1	H9606001	Presser foot lifting eccentric	1
F2	H9606002	Set screw	2
F3	H9606003	Eccentric connecting link	1
F4	H9606004	Screw	1
F5	H9606005	Washer	1
F6	H9606006	Nut	1
F7	H9606007	Adjusting crank	1
F8	H9606008	Screw	1
F9	H9606009	Presser foot lifting shaft	1
F10	H9606010	Presser foot lifting shaft crank	1
F11	H9606011	Screw	1
F12	H9606012	Presser foot lifting connecting link	1
F13	H9606013	Screw	2
F14	H9606014	Retaining ring-E type	4
F15	H9606015	Presser foot lifting lever	1
F16	H9606016	Screw	2
F17	H9606017	Presser foot lifting lever base	1
F18	H9606018	Screw	2
F19	H9606019	Roller	1
F20	H9606020	Bearing	1
F21	H9606021	Screw	1
F22	H9606022	Roller base plate	1
F23	H9606023	Screw	2
F24	H9606024	Walking foot lifting connecting link	1
F25	H9606025	Bushing	1
F26	H9606026	Set screw	1
F27	H9606027	Bushing	1
F28	H9606028	Set screw	1

G: NEEDLE BAR ROCK SHAFT MECHANISM

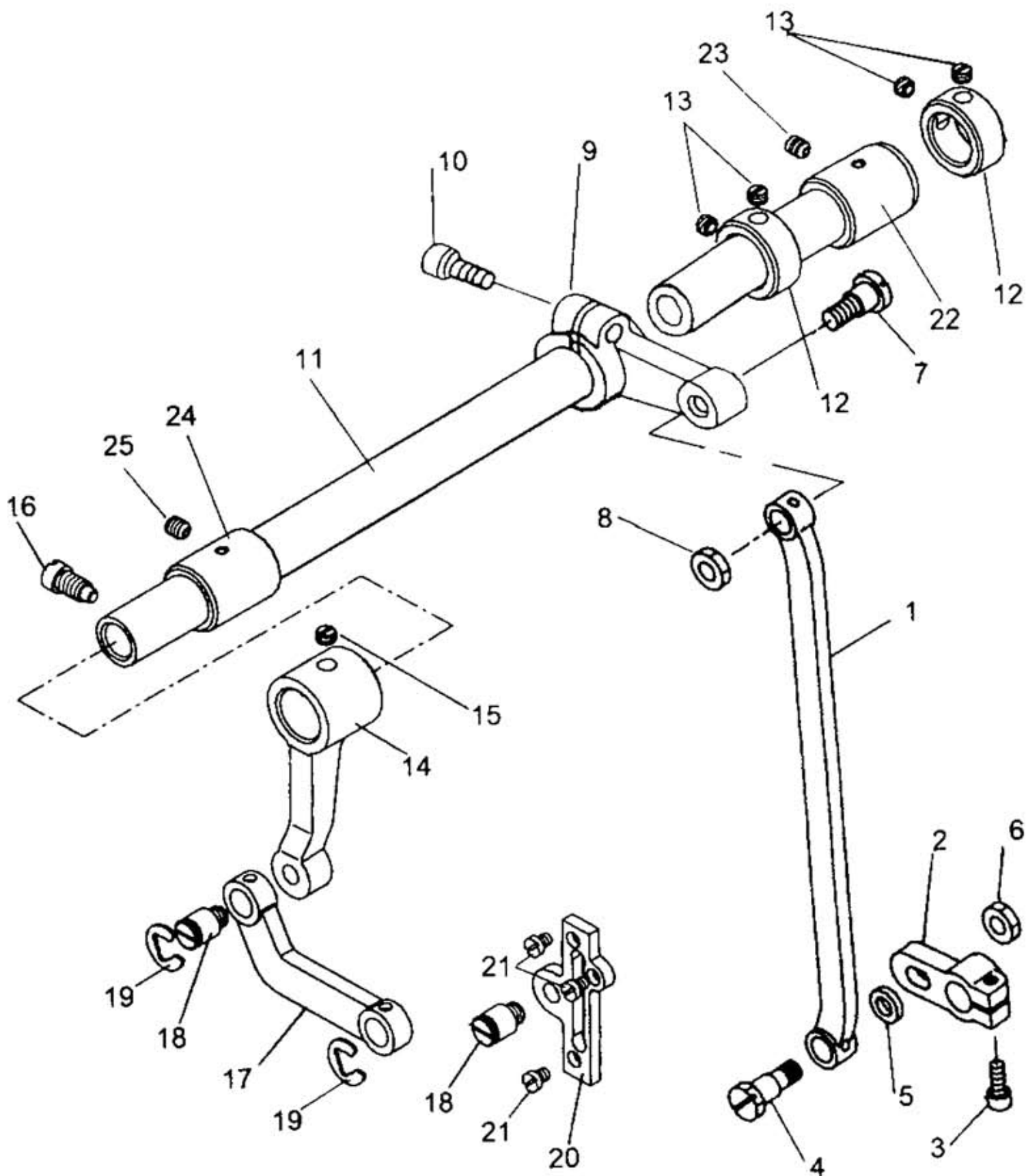

G: NEEDLE BAR ROCK SHAFT MECHANISM

No.	Ref. No.	Description	Pcs.
G1	H9607001	Needle bar rocking connecting link	1
G2	H9607002	Adjusting crank	1
G3	H9607003	Screw	1
G4	H9607004	Screw	1
G5	H9607005	Washer	1
G6	H9607006	Nut	1
G7	H9607007	Screw	1
G8	H9607008	Nut	1
G9	H9607009	Adjusting crank	1
G10	H9607010	Screw	1
G11	H9607011	Needle bar rock shaft	1
G12	H9607012	Collar	2
G13	H9607013	Set screw	4
G14	H9607014	Needle bar rocking crank	1
G15	H9607015	Set screw	1
G16	H9607016	Screw	1
G17	H9607017	Needle bar rocking connecting link	1
G18	H9607018	Screw	2
G19	H9607019	Retaining ring-E type	2
G20	H9607020	Screw base	1
G21	H9607021	Screw	3
G22	H9607022	Bushing	1
G23	H9607023	Set screw	1
G24	H9607024	Bushing	1
G25	H9607025	Set screw	1

H: KNEE LIFTER MECHANISM

