

ARTISAN

5550

High Speed Single Needle Lockstitch
Industrial Sewing Machine

Operator's Manual
and
Parts Book

1. MAIN SPECIFICATIONS

Item		GC128-M	GC128-H	GC128-B
Material weight		Typical	Heavy	Heavy
Max. sewing speed (spm)		5000	3500	3000
Needle		DB×1 No.14	DB×1 No.22	DB×1 No.22
Needle bar stroke (mm)		31.8	35	35
Lubrication Automatic lubrication, has reverse feeding mechanism				
Stitch length		0-5	0-8	0-8
Presser	By hand (mm)	5	6	6
	By knee (mm)	13	13	13
Bobbin				Double capacity of thread

2. INSTALL THE MOTOR (Fig.1)

Align Motor Pulley Groove (B) and Balance Wheel Groove (A) by moving the motor leftward or rightward.

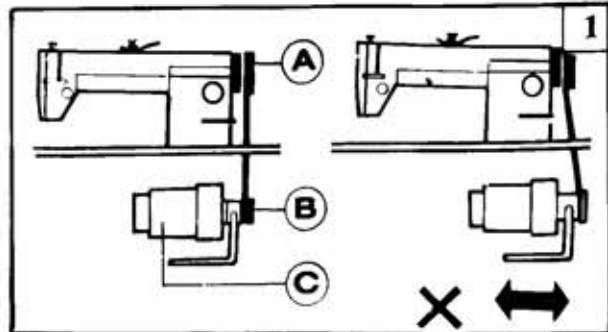

3. CONNECT THE CLUTCHLEVER WITH THE PEDAL (Fig. 2)

1) The optimum tilt angle of Pedal (A) is approximately 15 deg.

2) Adjust Clutch Cover (D) so that Clutch-Lever (C) and Draw Bar (B) run in line.

3) The balance wheel should rotate counter-clockwise when viewed from the outside of Balance Wheel (G). The direction of the motor pulley rotation can be reversed by reversing (turning over 180 deg.) the power plug of the motor.

4) Adjust the tension of V-belt (F) by turning Motor Vertical Position Screw (E). The proper tension of the V-belt is a slack of 10-20mm when the belt is depressed at the center of the belt by finger.

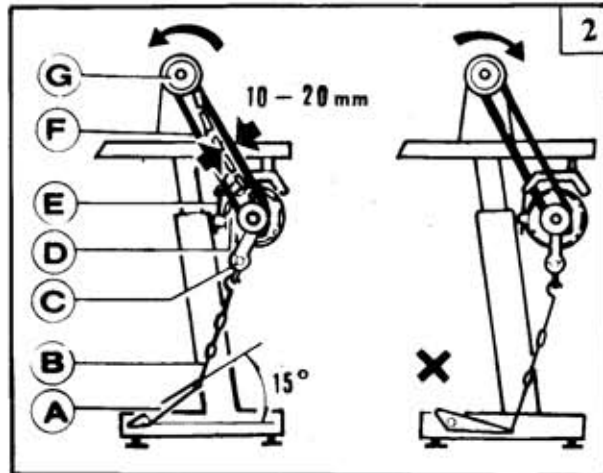

4. PREPARATION AND LUBRICATION (Fig.3)

1) Cleaning the machine

Before leaving the factory, the machine parts are coated with rust-preventive grease, which may be hardened and contaminated by dust during storage and shipment. This grease must be removed with gasoline.

2) Examination

Though every machine is confirmed by strict inspection and test before leaving the factory, the machine parts may be loose or deformed after long distance transportation with jolt. A thorough examination must be performed after cleaning the machine. Turn the balance wheel to see if there is running obstruction, parts collision, uneven resistance or abnormal noise. If these exist, adjustment must be made accordingly before run-in operation.

3) Oiling

(1) Required amount of oil

Line (A) on the oil reservoir: Max. oil level.

Line (B) on the oil reservoir: Min. Oil level.

If oil level goes down under Line (B), oil cannot be distributed to each part of the machine, thus causing the parts a seizure.

(2) Replenishing

Always use only No. 18 special machine oil for high speed sewing. Be sure to replenish oil to Line (A) before starting operation.

(3) Replacing oil

To replace oil, remove Screw (C) to drain oil. After completely draining off oil, clean the oil reservoir and securely tighten Screw (C), then fill the reservoir with fresh oil.

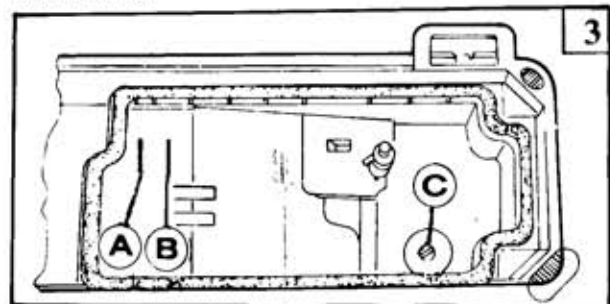

5. REPLACE NEEDLES (Fig.4)

Turn the balance wheel to lift needle bar to the upper end of its stroke. Loosen Needle Clamp Screw A. While keeping the long groove of the needle leftward fully insert the needle shank up to the bottom of the needle socket. Then tighten Needle Clamp Screw A.

Note: Fig. (b): insufficient insertion.

Fig. (c): wrong direction of long groove.

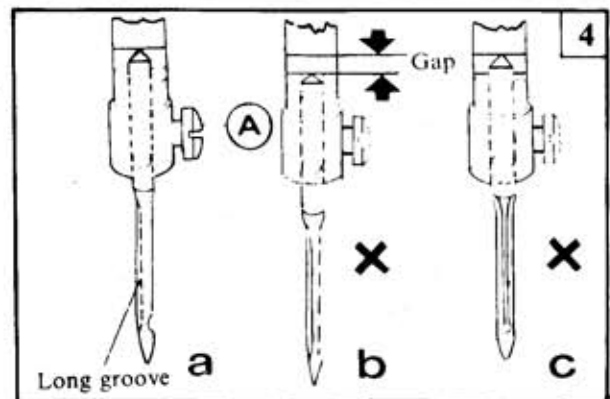

6. NEEDLE, THREAD AND MATERIAL TO BE SEWN

Needle Size	Thread Number	Material
No.9	No.100-No.80	Georgette, Hard Crepe
No.11	No.80-No.60	Silk, Muslin, Poplin
No.14	No.60-No.50	Cotton, Woolen
No.16	No.50-No.30	Woolen, Tarpaulin, Thin Leather

7. RUN-IN OPERATION (Fig. 5)

Run-in operation is required for a new sewing machine, or a sewing machine left out of operation for a considerable length of time.

1) Remove Red Rubber Plugs (A) on the top of the arm and replenish sufficient amount of oil.

2) Lift Presser Foot (B)

3) Run the machine at a low speed (40% - 50% of Max. speed) to check oil distributing condition through Oil Check Window (C).

4) Perform run-in operation at 40% - 50% of Max. speed 30 minutes. After a lapse of one month of service during which the working speed is increased gradually and the machine runs sufficiently well, the Max. speed can be adopted according to the nature of the work.

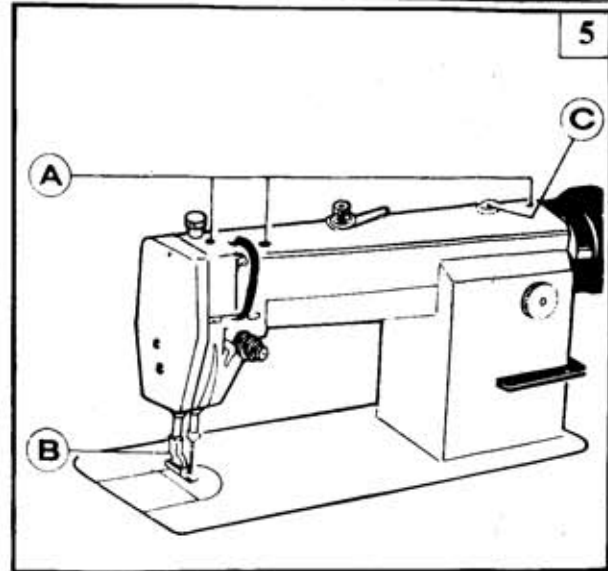

8. THREADING (Fig. 6)

To thread the needle thread, raise needle bar to the upper end of its stroke, lead the thread from spool and perform threading as shown in Fig. 6. To draw the bobbin thread, hold the end of the needle thread and turn the balance wheel to lower the needle bar and then to lift it to its highest position. Pull the needle thread and the bobbin thread is drawn up. Put the ends of needle thread and bobbin thread forward under presser foot.

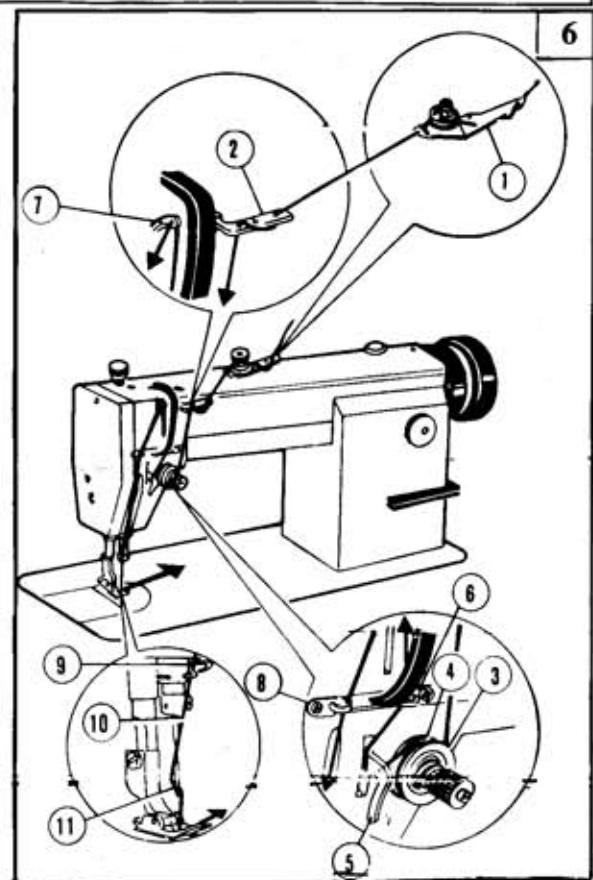

9. WINDING ADJUSTMENT (Fig. 7)

1) The wound bobbin thread should be neat and tight, if not, adjust the winding tension by turning Tension Stud Nut (A) of bobbin winder tension bracket.

Note: nylon or polyester thread should be wound with little tension, otherwise, Bobbin (D) might break or deform.

2) When the wound thread layer does not present a cylindrical shape as shown in Fig. 7 (a), loosen Set Screw (B) of bobbin winder tension bracket and slide Bracket (C) leftward or rightward. If thread is wound as shown in Fig. 7 (b), move the bracket rightward, but if thread is wound as shown in Fig. 7 (c), move the bracket leftward.

After adequately positioning the bracket, tighten Set Screw (B).

3) Do not overfill the bobbin. The optimum length of thread will fill about 80% of bobbin capacity. This can be adjusted by Adjusting Screw (E) of bobbin winder stop latch.

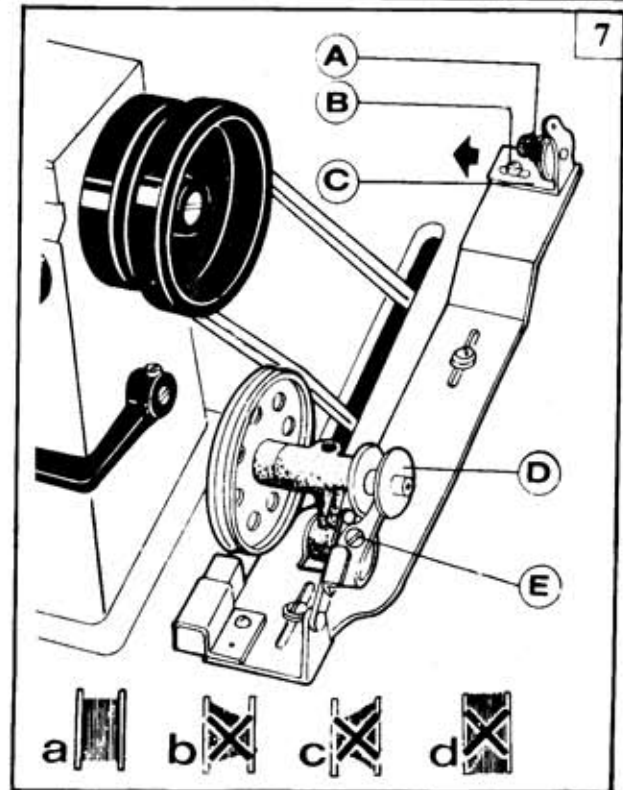

10. SET STITCH LENGTH AND REVERSE FEEDING (Fig. 8)

1) Stitch length can be set by turning Dial (A).

2) The figures on Face (B) of dial show stitch length in mm.

3) Reverse feeding starts when Reverse Feed Lever (C) is depressed, and the machine will feed forward again if Reverse Feed lever (C) is released.

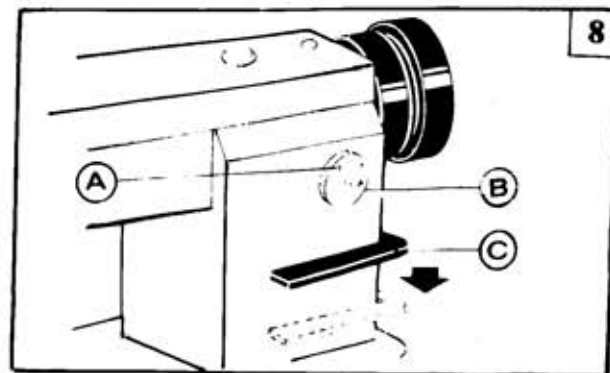

11. POSITION PRESSER BAR (Fig. 9)

- 1) Loosen Lock Nut (E) and Pressure Regulating Thumb Screw (A).
- 2) Remove rubber plug from Face Plate (B).
- 3) Loosen Screw (C) and adjust the position of Presser Bar till the presser foot is 5.0mm(GC128-M: 5.0mm, GC128-H and GC128-B: 6.0mm) above the throat plate with the presser foot lifted to its highest.
- 4) Tighten Screw (C) and put in the rubber plug.
- 5) Tighten Pressure Regulating Thumb Screw (A) and Lock Nut (E).

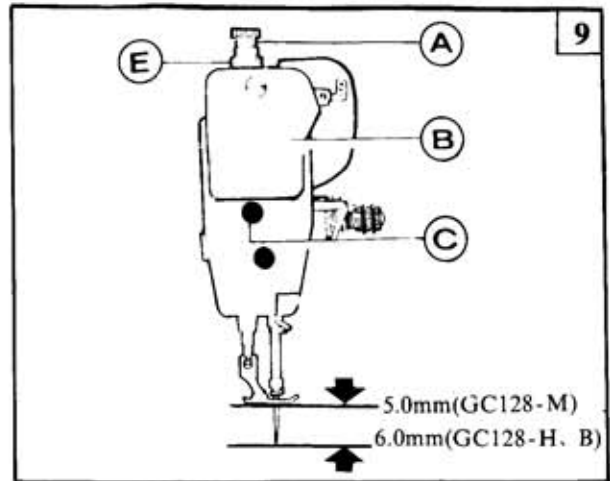

12. ADJUST THE PRESSURE OF PRESSER FOOT (Fig. 10)

Pressure of presser foot is to be adjusted in accordance with thickness of materials to be sewn.

First loosen Lock Nut (A). For heavy materials, turn the pressure regulating thumb screw as shown in Fig. 10 (a) to increase the pressure, while for light materials, turn the pressure regulating thumb screw as shown in Fig. 10 (b) to decrease the pressure. Then tighten Lock Nut (A).

The pressure of presser foot is recommended to be less as long as normal feeding is ensured.

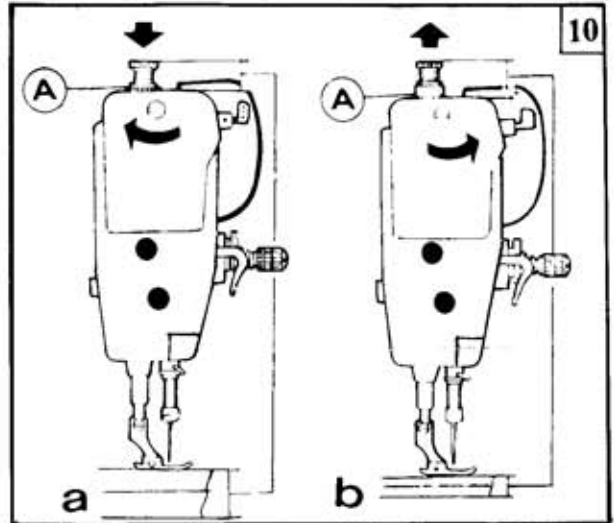

13. ADJUST THREAD TENSION (Fig. 11, 12)

In principle, thread tension is to be adjusted in accordance with materials, thread and other factors.

In practice, thread tension is adjusted according to the stitches obtained. The needle thread tension should be adjusted with reference to the bobbin thread tension. Turn Tension Spring Regulating Screw (A) of bobbin case clockwise for more tension, or turn the screw counter-clockwise for less tension.

It is common practice to test the bobbin thread tension as shown in Fig. 12. Hold the end of the thread from delivery eye. If the bobbin case is falling slowly, the proper tension is obtained. The needle thread tension can be adjusted by setting (1) the thread take-up spring tension, (2) the thread take-up spring stroke and (3) tension spring. All these adjustments will be described in the following.

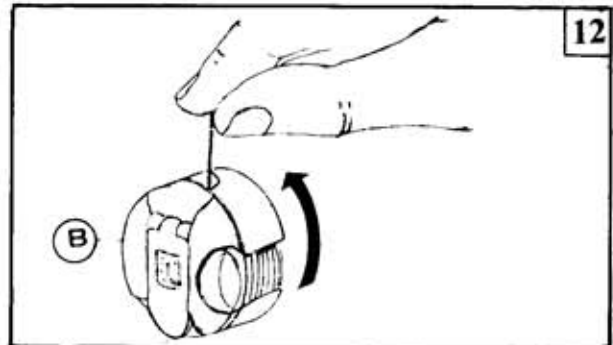
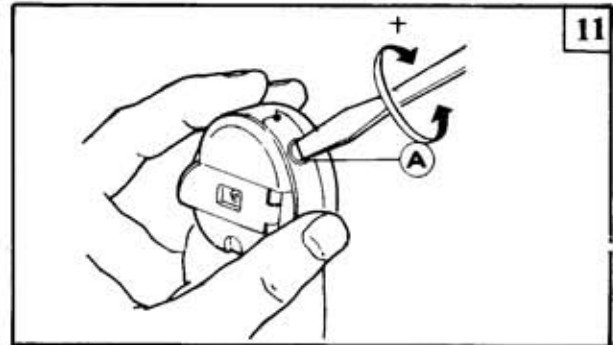

14. ADJUST THREAD TAKE-UP SPRING (Fig. 13, 14)

1) Adjusting the thread take-up spring tension

Loosen Set Screw (A), turn Tension Stud (B) clockwise to increase the spring tension, or turn the stud counter-clockwise to decrease the spring tension. After the adjustment, be sure to tighten Set Screw (A). The thread take-up spring tension should be about 30g. To Attain this, first loosen Set Screw (A), turn Tension Stud (B) counter-clockwise to decrease the tension of Thread Take-up Spring (C) to zero, then turn Tension Stud (B) clockwise until Spring (C) comes to the notch of thread tension regulating bushing, and again turn Tension Stud (B) halfway back (counter-clockwise) After the adjustment, tighten Set Screw (A).

2) Adjusting the thread take-up spring stroke

Loosen Set Screw (B), turn Stud (C) clockwise to increase the stroke or turn Stud (C) counter-clockwise to decrease the stroke. After the adjustment, tighten Set Screw (B).

Before leaving the factory, the thread take-up spring has properly been adjusted. Readjustment is needed only in the case of special material or special thread.

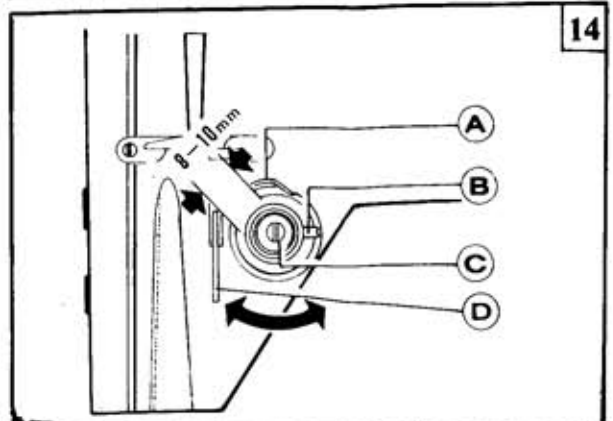
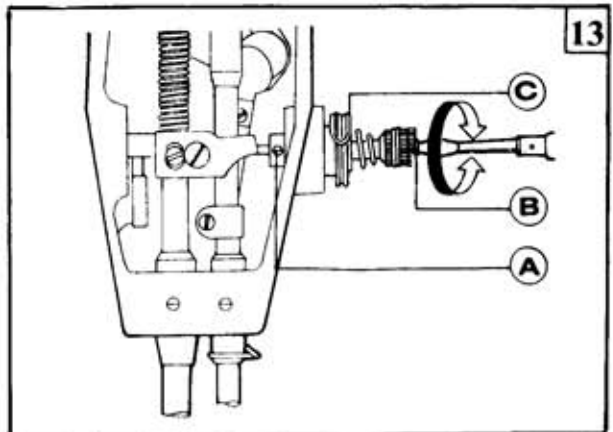

15. ADJUST THREAD GUIDE AND THREAD TENSION (Fig.15,16)

The position of the thread guide affects stitch tightness and therefore must be adjusted according to sewing materials and sewing conditions.

	1	2	3
Thread guide position	Leftward	Center	Rightward
Material weight	Heavy	Medium	Light

Fig. 15 shows different stitch forms. Normal stitch form should be as shown in Fig. 15 (a). When abnormal stitches cause puckering and thread breakage, the tension of needle thread and bobbin thread must be adjusted accordingly.

1) In case needle thread tension is too strong or bobbin thread tension is too weak, as shown in Fig. 15 (b), turn the thumb nut counterclockwise to decrease the needle thread tension, or tighten the tension spring regulating screw of bobbin case to increase the bobbin thread tension (See Fig. 16)

2) In case needle thread tension is too weak or bobbin thread tension is too strong, as shown in Fig. 15 (c), turn the thumb nut clockwise to increase the needle thread tension, or loosen the tension spring regulating screw or bobbin case to decrease the bobbin thread tension.

3) In case of the stitch forms as shown in Fig. 15 (d) and (e), adjustments can be made with reference to the above means.

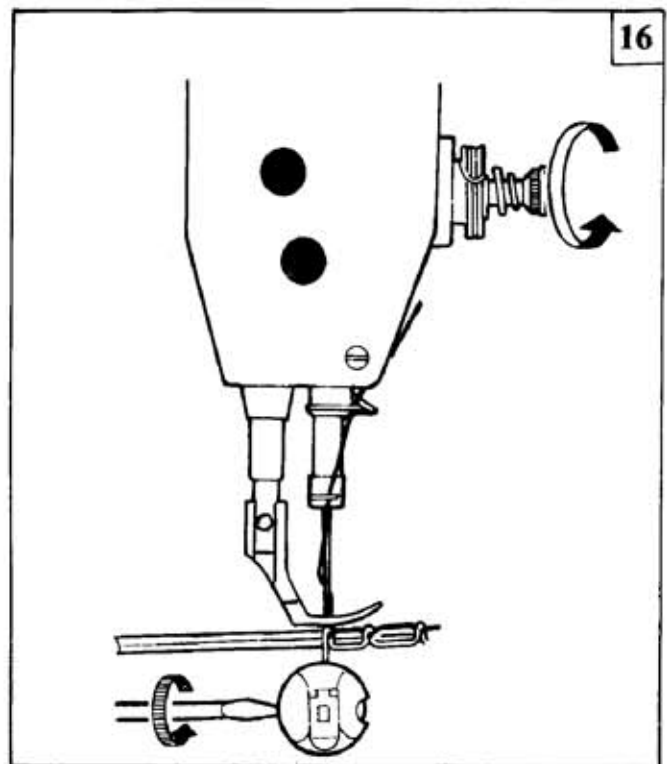
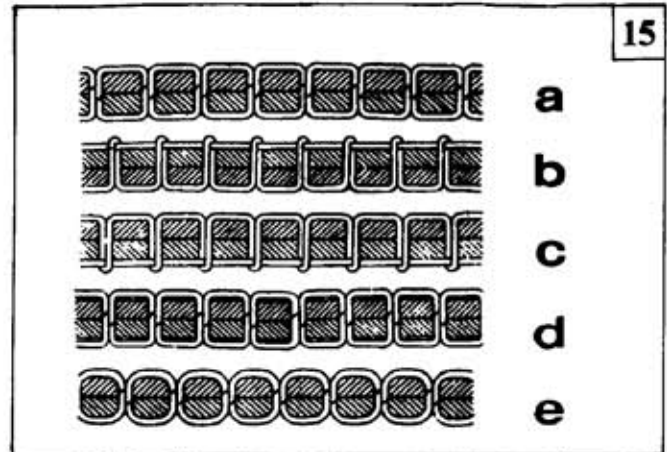

16. TIME NEEDLE TO ROTATING HOOK (Fig. 17,18,19,20)

A. Adjusting the needle position (See Fig.17)

- 1) Turn balance wheel by hand to bring Needle Bar (C) to the lowest position of its stroke.
- 2) Remove rubber plug from Face Plate (A)
- 3) Loosen Set Screw (B) of needle bar adaptor.
- 4) Move Needle Bar (C) vertically to adjust needle timing.

5) After the adjustment, tighten Set Screw (B) and put in the rubber plug. The standard needle timing (See Fig. 18) is to align Timing Mark (B) on the needle bar and the bottom of Needle Bar Bushing (A) and meanwhile align the Inner Surface (E) of the hook and the center of Needle Eye (D) when the needle bar gets down to its lowest position.

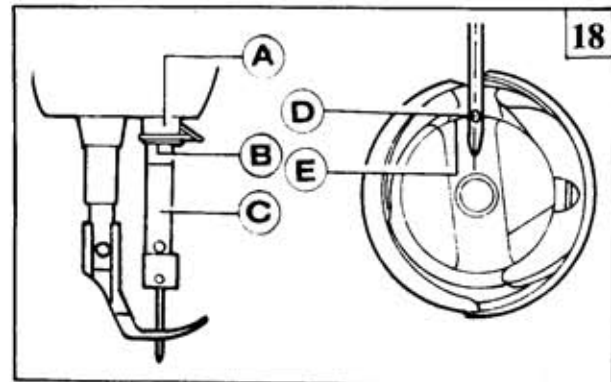
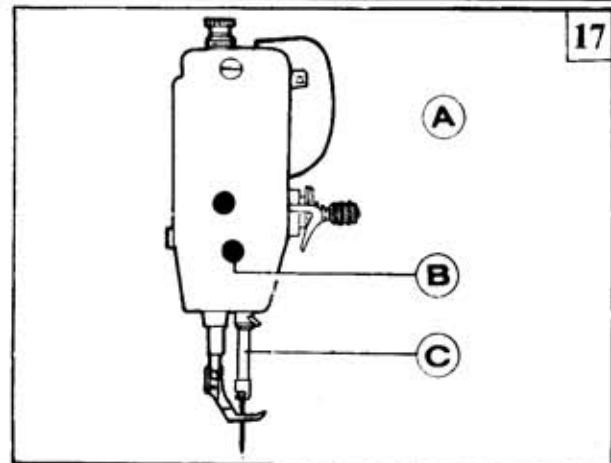

B. Adjusting the hook point timing

Timing of needle motion to rotating hook motion has a great effect on sewing performance. The standard hook point timing (See Fig.19) is to align Hook Point (D) and Needle Centerline (C) when Needle Bar (B) is lifted by 2.2mm (GC128-B:2.2mm, GC128-M and Gc128-H: 2.4mm) of its stroke. (2.4 mm suitable for type B and type C). Besides, Hook Point (D) should be 1.0-1.5mm above the upper end of needle eye (E).

When adjusting the hook point timing, also notice that the clearance between the bottom of needle notch and Hook Point (C) should be approx 0.05mm (See Fig.20)

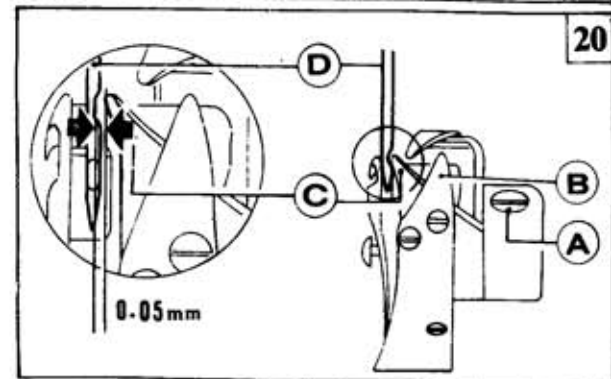
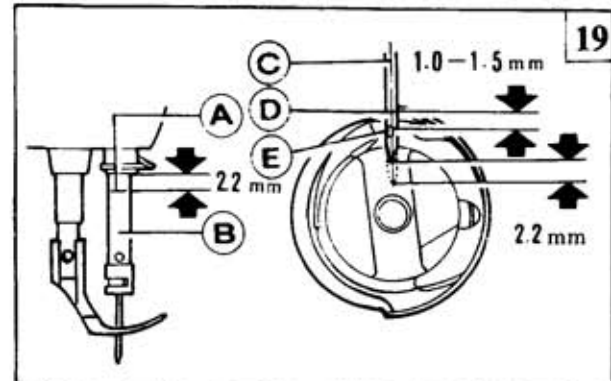

17. REPLACE ROTATING HOOK (Fig.21)

1) Lift needle bar to the highest position of its stroke. 2) Remove throat plate, take down needle and bobbin case.

3) Loosen Screw (C) of hook positioner and take down Hook Positioner (A).

4) Loosen two Screws (D) of rotating hook.

5) Turn balance wheel to raise feed bar to its highest position, then take down the rotating hook by turning it away from feed bar.

6) Installing the hook can be done in reverse sequence. Note that Needle (B) and the convex surface of Hook Positioner (A) should align with a clearance of 0.5 – 0.7mm between them.

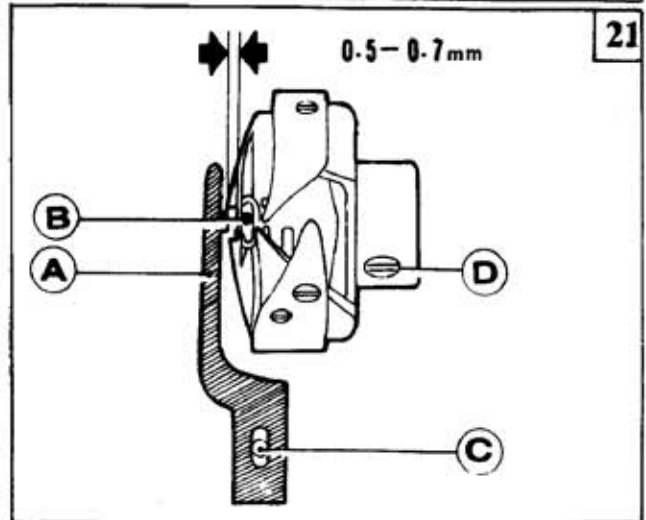

18. ADJUST THE HEIGHT OF FEED DOG (Fig. 22,23)

1) Turn balance wheel until feed dog is lifted to its highest position from throat plate surface.

2) Loosen Screw (A) of feed lifting rock shaft crank right (See Fig. 22, b)

3) Move Feed Bar (B) in the direction shown by the arrow in Fig. 22 (a) to adjust the height of the feed dog. The standard height of feed dog is that the top of feed dog is 1.0mm above Throat Plate Surface (B).

4) After the adjustment, be sure to tighten Screw (A).

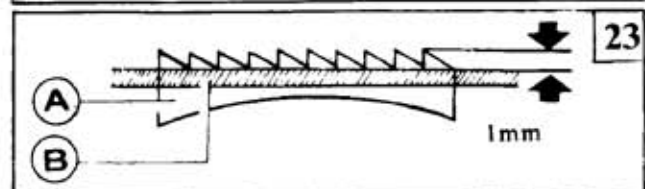
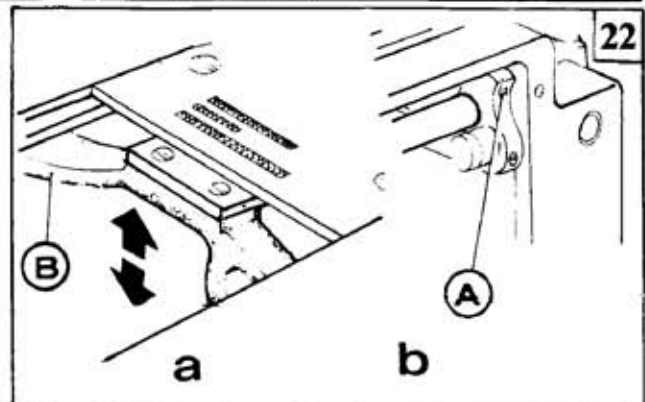

19. ADJUST THE POSITION OF FEED DOG (Fig.24, 25)

The standard position of feed dog is that the clearance between the front end of the throat plate slot and the first tooth of the fully advanced feed dog is 0.8mm, as shown in Fig. 24.

1) Fully advance the feed dog toward the front end of the throat plate slot.

2) Loosen Feed Rock Shaft Crank Screw (A). See Fig. 25 (b).

3) Move Feed Bar (B) in the direction shown by the arrow in Fig. 25 (a) to adjust the feed dog position.

4) After the adjustment, be sure to tighten Screw (A).

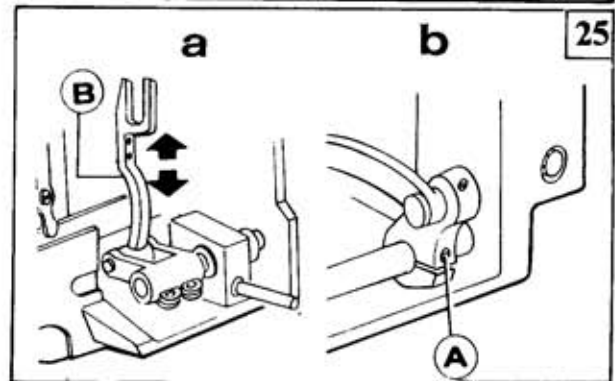
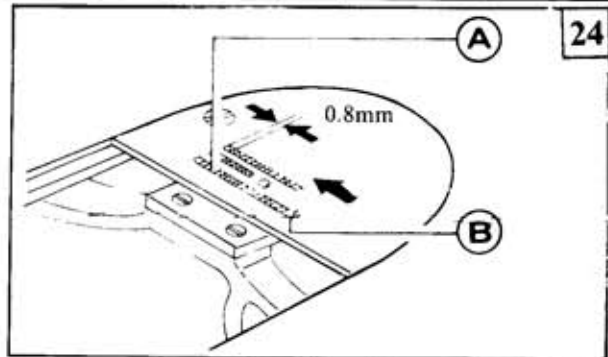

20. TIME FEED MOTION TO NEEDLE MOTION (Fig.26, 27, 28)

The standard timing of feed motion to needle motion is that the top of Feed Dog (C) is flush with Throat Plate Surface (B) when the point of Needle (A) reaches Throat Plate Surface (B). See Fig.26

If feed motion is not timed to needle motion, adjust as follows (See Figs. 27 and 28)

1) Remove Arm Side Cover (F).

2) Loosen Set Screws (A) and (D) of feed and feed lifting eccentric.

3) Hold Feed and Feed Lifting Eccentric (B) and turn Balance Wheel (E) slowly until the upper edge of Arm Shaft Oil Hole (C) aligns with the lower edge of Reference Hole (G) of feed and feed lifting eccentric.

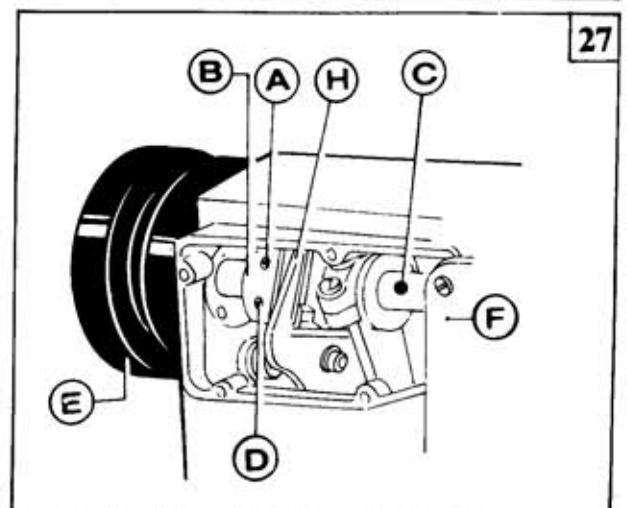
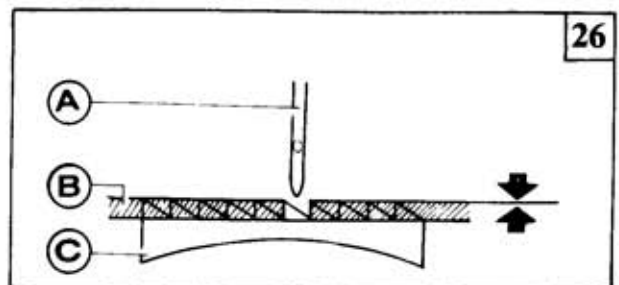

4) Leave a clearance of 0.3-0.5mm between Feed and Feed Lifting Eccentric (B) and Eccentric Sleeve (H), then tighten Set Screws (A) and (D).

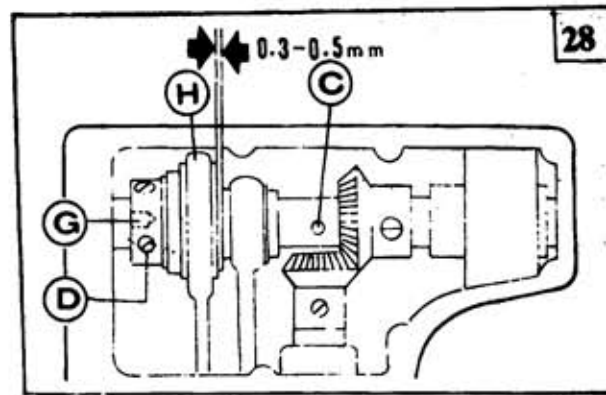

21. ADJUST OPENING TIME OF THE TENSION DISCS (Fig. 29)

Within the presser foot lift range of 2-7mm opening time of the tension discs can be adjusted as follows:

- 1) Remove the rubber plug from the back of arm and loosen Screw (A) of knee lifter lever (left).
- 2) Move the tension releasing cam leftward for earlier opening or rightward for later opening. It will facilitate the adjustment to put under the presser foot a block as thick as the presser foot lift.
- 3) After the adjustment, fully tighten Screw (A).

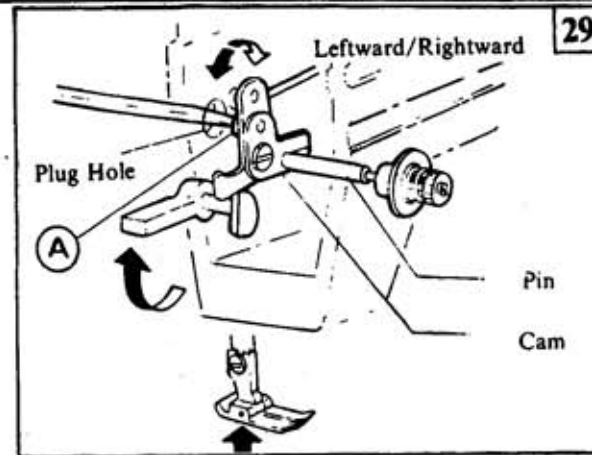

22. LUBRICATION ADJUSTMENT (Fig. 30)

Adjusting the lubrication of rotating hook

The lubrication of the rotating hook can be adjusted by Oil Adjusting Screw (A) as follows:

- 1) Turn Oil Adjusting Screw (A) clockwise to increase oil and turn Oil Adjusting Screw (A) counterclockwise to decrease oil.
- 2) Oil Adjusting Screw (A) adjusts oil amount within 5 turns. When Oil Adjusting Screw (A) is fully tightened, oil amount is maximum.
- 3) Readjustment depends on temperature, sewing speed and the like. In practice, oil amount can be judged as follows: remove the throat plate and place a piece of paper on instead, run the machine for about 20 seconds, then check the oil splashed on the paper.

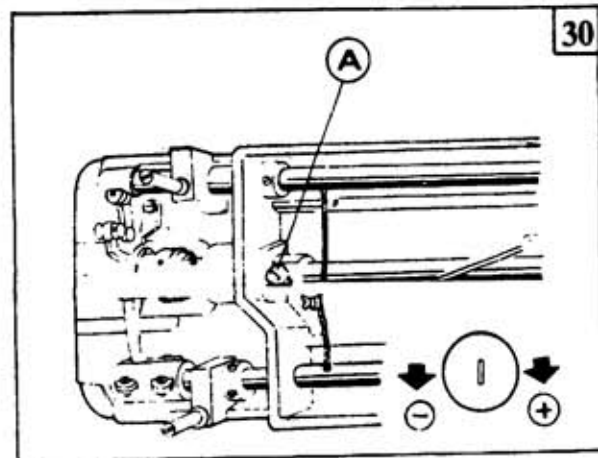

23. REGULAR CLEANING (Fig.31, 32, 33)

1) Cleaning feed dog (See Fig.31)

Remove the throat plate and clear off the dust and lint between feed dog tooth slots.

2) Cleaning rotating hook (See Fig.32)

Swing out the machine head and clean the hook.

Wipe the bobbin case with soft cloth.

3) Cleaning oil pump screen (See Fig.33)

Swing out the machine head and clear off the dust and dirt on the oil pump screen.

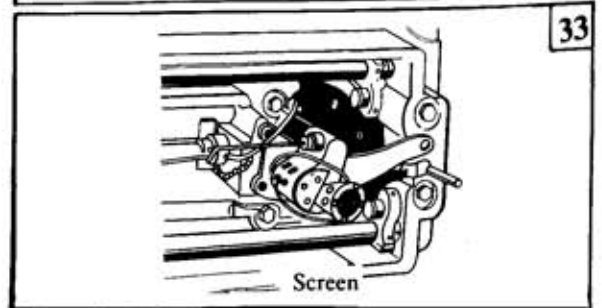
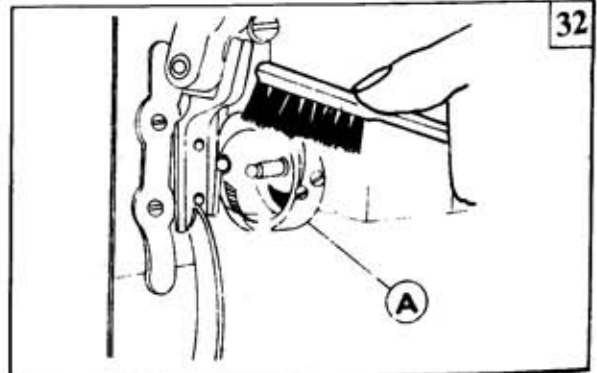
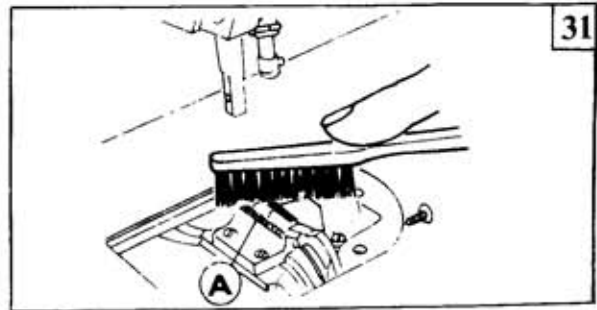

C O N T E N T S

1. MACHINE FRAME & MISCELLANEOUS COVER COMPONENTS.....	1
2. MAIN SHAFT & THREAD TAKE-UP LEVER COMPONENTS.....	3
3. NEEDLE BAR & HOOK DRIVING SHAFT COMPONENTS.....	5
4. HAND LIFTER COMPONENTS.....	7
5. FEED MECHANISM COMPONENTS.....	9
6. OIL LUBRICATION COMPONENTS.....	11
7. OIL RESERVOIR COMPONENTS.....	13
8. BELT COVER & BOBBIN WINDER COMPONENTS.....	15
9. THREAD STAND COMPONENTS.....	16
NUMERICAL INDEX OF PARTS.....	17

1. MACHINE FRAME & MISCELLANEOUS COVER COMPONENTS

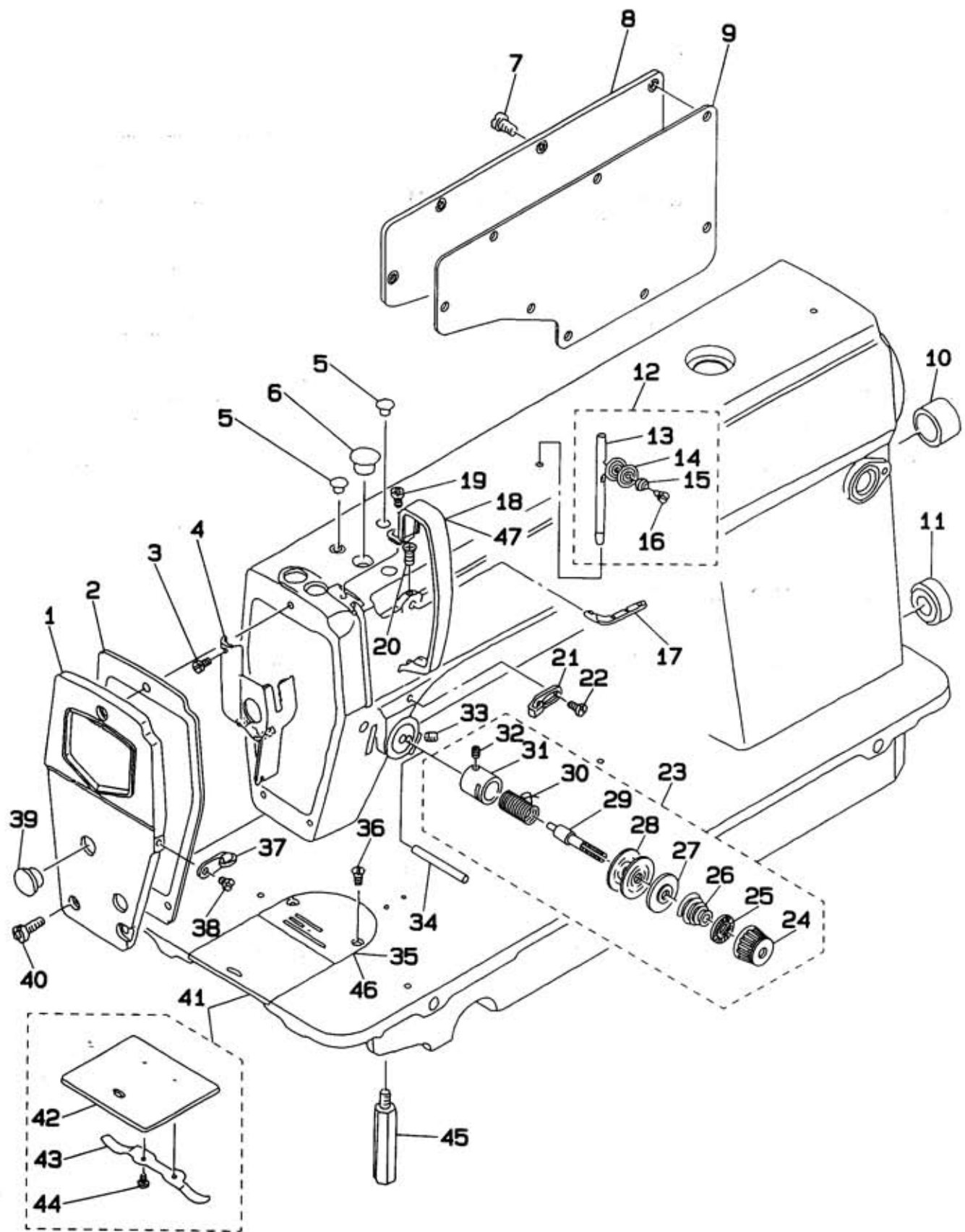

REF. NO. NOTE	PART NO.	D E S C R I P T I O N	AMT.
1	110-00254	FACE PLATE ASM.	1
2	110-00304	FACE PLATE GASKET	1
3	SS-6080410-SP	SCREW 1/8-44 L=4	1
4	110-00858	ARM OIL SHIELD ASM.	1
5	TA-0850604-R0	RUBBER PLUG	2
6	TA-1250705-R0	RUBBER PLUG	1
7	SS-4120915-SP	SCREW 12/64-28 L=9	8
8	110-00510	SIDE PLATE	1
9	110-00619	GASKET	1
10	TA-2000502-R0	RUBBER PLUG	1
11	TA-2101002-R0	RUBBER PLUG	1
12	B1113-155-0A0	NEEDLE THREAD GUIDE PIN ASM.	1
13	B1113-155-000	NEEDLE THREAD GUIDE PIN	(1)
14	B3148-123-000	TENSION DISC	(2)
15	B3149-123-A00	TENSION SPRING	(1)
16	SD-0380552-SL	HINGE SCREW D=3.8 H=5.5	(1)
17	110-18702	THREE-HOLE THREAD EYELET	1
18	110-00700	THREAD TAKE-UP LEVER COVER	1
19	SS-4120615-SP	SCREW 3/16-28 L=6	1
20	SS-4120615-SP	SCREW 3/16-28 L=6	1
21	110-18504	ARM THREAD GUIDE A	1
22	110-01500	SCREW	1
23	110-18959	THREAD TENSION ASM.	1
24	110-18900	TENSION NUT	(1)
25	B3120-125-000	TENSION DISC STOPPER	(1)
26	B3129-012-A00	TENSION SPRING	(1)
27	B3132-552-000	TENSION DISC HOLDER	(1)
28	B3126-012-000	TENSION DISC	(2)
29	B3115-552-000	TENSION POST	(1)
30	B3128-012-000	TAKE-UP SPRING	(1)
31	B3111-552-B00	TENSION POST SOCKET	(1)
32	SS-8090670-SP	SCREW 9/64-40 L=5.5	(1)
33	SS-8150710-SP	SCREW 15/64-28 L=7	1
34	B3118-552-E00	THREAD RELEASE PIN	1
35	B1109-012-A00	THROAT PLATE (A)	1
36	SS-2110920-TP	SCREW 11/64-40 L=8.5	2
37	110-18603	ARM THREAD GUIDE B	1
38	SS-6110610-TP	SCREW 11/64-40 L=6	1
39	TA-1250406-R0	RUBBER PLUG	2
40	SS-4120915-SP	SCREW 12/64-28 L=9	3
41	110-01658	BED SLIDE ASM.	1
42	B1110-012-000	SLIDE PLATE	(1)
43	110-01609	BRED SLIDE SPRING	(1)
44	SS-6060210-SP	SCREW 3/32-56 L=1.9	(2)
45	110-01104	BED SCREW STUD	4

2. MAIN SHAFT & THREAD TAKE-UP LEVER COMPONENTS

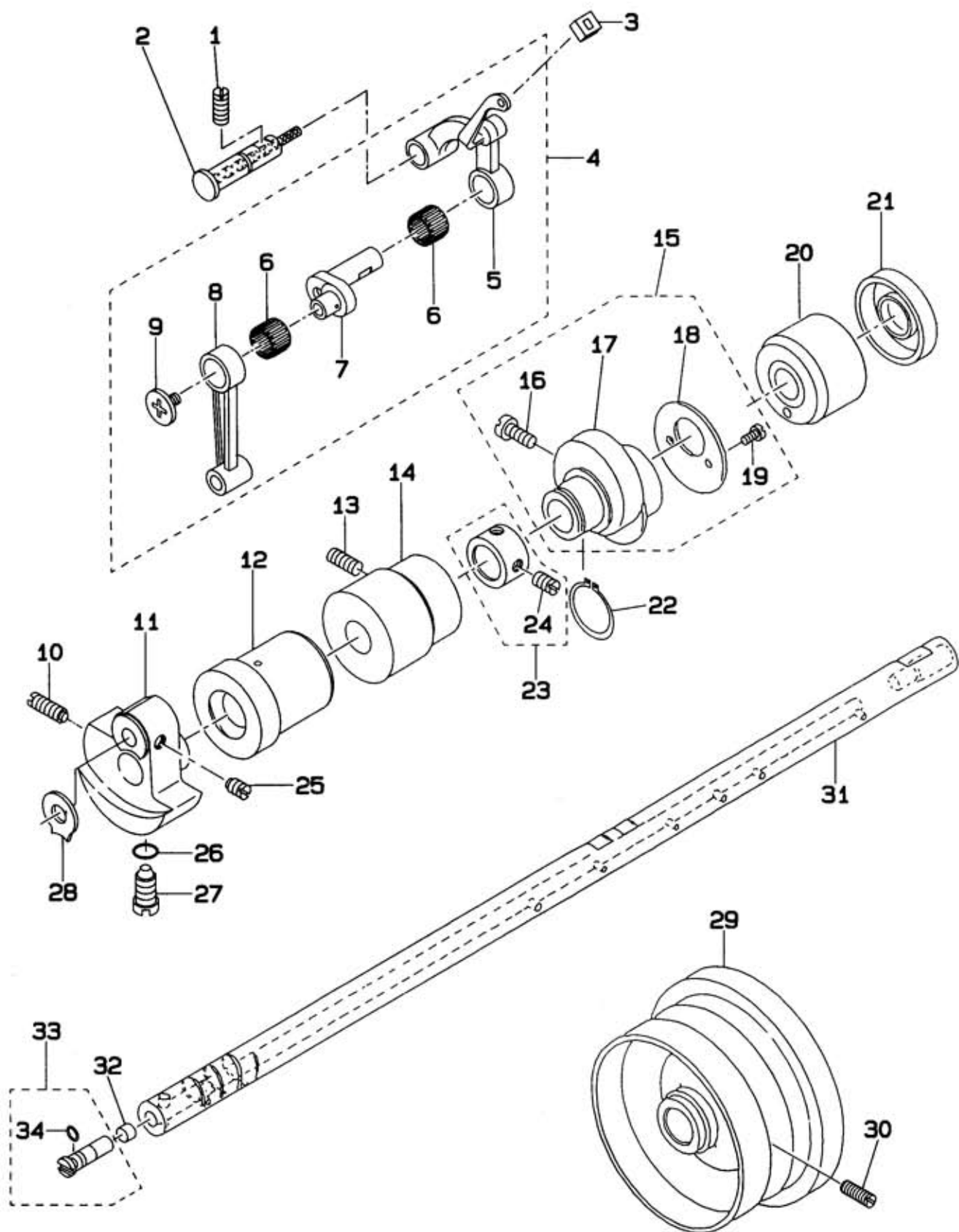

REF. NO. NOTE	PART NO.	D E S C R I P T I O N	AMT.
1	SS - 8151150 - SP	SCREW 15/64 - 28 L=10.5	1
2	110 - 17209	THREAD TAKE - UP CRANK SHAFT	1
3	CQ - 3500000 - F0	OIL FELT	0.1
4	110 - 39070	THREAD TAKE - UP LEVER ASM.	1
5	110 - 39062	THREAD TAKE - UP LEVER ASM.	(1)
6	B1905 - 541 - B00	NEEDLE BEARING, B	(2)
7	110 - 05204	NEEDLE BAR CRANK	(1)
8	B1408 - 552 - 000	NEEDLE BAR CRANK ROD	(1)
9	B1903 - 552 - 000	END SCREW LEFT	(1)
10	SS - 8681650 - TP	SCREW 9/32 - 28 L=16	1
11	110 - 02706	COUNTERWEIGHT	1
12	110 - 02201	MAIN SHAFT BUSHING, FRONT	1
13	SS - 8150912 - TH	SCREW	1
14	110 - 02300	BUSHING, INTERMEDIATE	1
15	110 - 08059	FEED DRIVE ECCENTRIC CAM ASM.	1
16	SS - 6661110 - SP	SCREW 1/4 - 40 L=11	(2)
17	110 - 08000	FEED DRIVE ECCENTRIC CAM	(1)
18	110 - 08109	THRUST COLLAR	(1)
19	SS - 6090670 - TP	SCREW 9/64 - 40 L=16	(2)
20	110 - 02805	MAIN SHAFT BUSHING, REAR	1
21	110 - 02508	OIL SEAL	1
22	RC - 1850001 - KP	SNAP RING 18.5	1
23	CS - 147121A - SH	THRUST COLLAR ASM. D=14.72 W=12	1
24	SS - 8660610 - TP	SCREW 1/4 - 40 L=6	(2)
25	SS - 8660610 - TP	SCREW 1/4 - 40 L=6	2
26	RO - 0442401 - 00	RUBBER RING	1
27	SS - 7681650 - TP	SCREW 9/32 - 28 L=6	1
28	B1212 - 552 - A00	COUNTERWEIGHT PROTECTING PLATE	1
29	110 - 02607	HAND WHEEL	1
30	SS - 8151550 - SP	SCREW 15/64 - 28 L=15	2
31	110 - 02003	MAIN SHAFT	1
32	110 - 02904	ROLLER FELT	1
33	B1213 - 552 - 0A0 - A	OIL AMOUNT ADJUSTING PIN ASM.	1
34	RO - 0291801 - 00	RUBBER RING	(1)

3. NEEDLE BAR & HOOK DRIVING SHAFT COMPONENTS

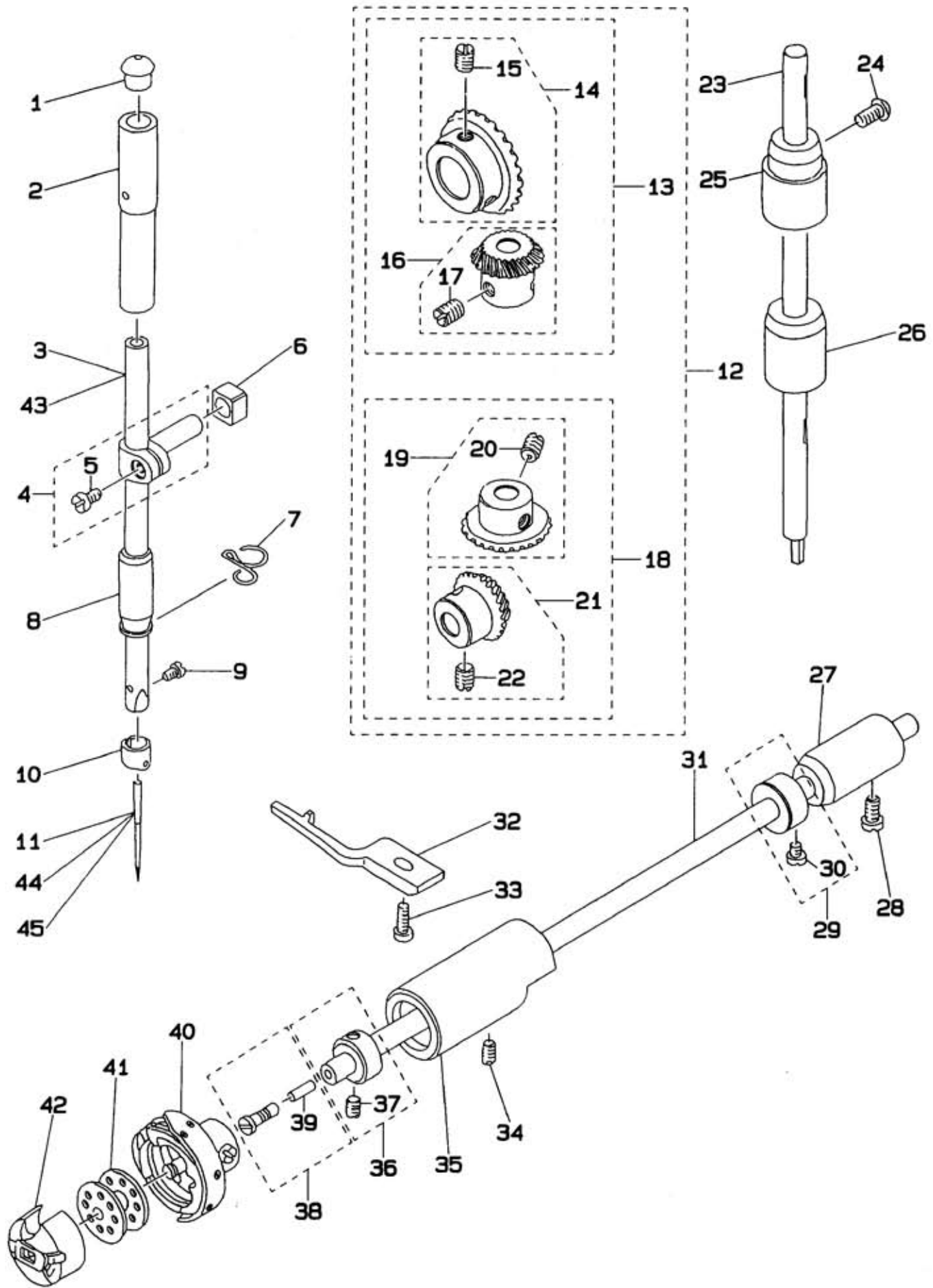

REF. NO. NOTE	PART NO.	D E S C R I P T I O N	AMT.
1	B1405 - 012 - 000	CAP	1
2	B1402 - 552 - 000 - A	NEEDLE BAR BUSHING. UPPER	1
3	110 - 05006	NEEDLE BAR	1
4	B1411 - 552 - 0A0	NEEDLE BAR CONNECTION ASM.	1
5	SS - 6090670 - TP	SCREW 9/64 - 40 L=6	(1)
6	B1414 - 555 - 000	SLIDE BLOCK	1
7	110 - 18801	NEEDLE BAR THREAD GUIDE	1
8	B1403 - 155 - 000	NEEDLE BAR BUSHING. LOWER	1
9	SS - 7080510 - TP	SCREW 1/8 - 44 L=4.5	1
10	110 - 05303	NEEDLE BAR THREAD GUIDE	1
11	MDB - 100B1400	NEEDLE DBX1 #14	1
12	B1306 - 155 - 0C0	GEAR & PINION ASM.	1
13	B1306 - 155 - 0B0	GEAR & PINION ASM., UPPER	(1)
14	B1305 - 012 - 0A0	GEAR ASM.	(1)
15	SS - 8660810 - TP	SCREW 1/4 - 40 L=8	(2)
16	B1306 - 155 - 0A0	PINION ASM.	(1)
17	SS - 8660810 - TP	SCREW 1/4 - 40 L=8	(2)
18	B1307 - 155 - 0B0	GEAR & PINION ASM., LOWER	(1)
19	B1307 - 155 - 0A0	GEAR ASM. LARGE	(1)
20	SS - 8660810 - TP	SCREW 1/4 - 40 L=8	(2)
21	B1308 - 155 - 0A0	PINION ASM.	(1)
22	SS - 8660810 - TP	SCREW 1/4 - 40 L=8	(2)
23	110 - 04009	UPRIGHT SHAFT	1
24	SS - 4120915 - SP	SCREW 12/64 - 28 L=9	1
25	110 - 04108	BUSHING, UPPER	1
26	110 - 04207	UPRIGHT SHAFT BUSHING, LOWER	1
27	110 - 15203	BUSHING, REAR	1
28	SS - 4120915 - SP	SCREW 12/64 - 28 L=9	1
29	CS - 079101A - SH	THRUST COLLAR ASM. D=7.94 W=10	1
30	SS - 6110420 - TP	SCREW 11/64 - 40 L=4.8	(2)
31	110 - 15005	HOOK DRIVING SHAFT	1
32	110 - 15609	POSITIONING FINGER	1
33	SS - 6111010 - SP	SCREW 11/64 - 40 L=9.5	1
34	SS - 8150432 - TH	SCREW	1
35	110 - 15104	BUSHING ASM., FRONT	1
36	CS - 079073A - SH	THRUST COLLAR	1
37	SS - 8110410 - TP	SCREW 11/64 - 40 L=3.5	(2)
38	B1808 - 552 - 0A0	OIL SEAL SCREW ASM.	1
39	B1810 - 552 - 000	OIL WICK	(1)
40	B1830 - 127 - 0A0	HOOK ASM.	1
41	B9117 - 012 - 000	BOBBIN	1
42	B1837 - 012 - 0A0	BOBBIN CASE ASM.	1

4. HAND LIFTER COMPONENTS

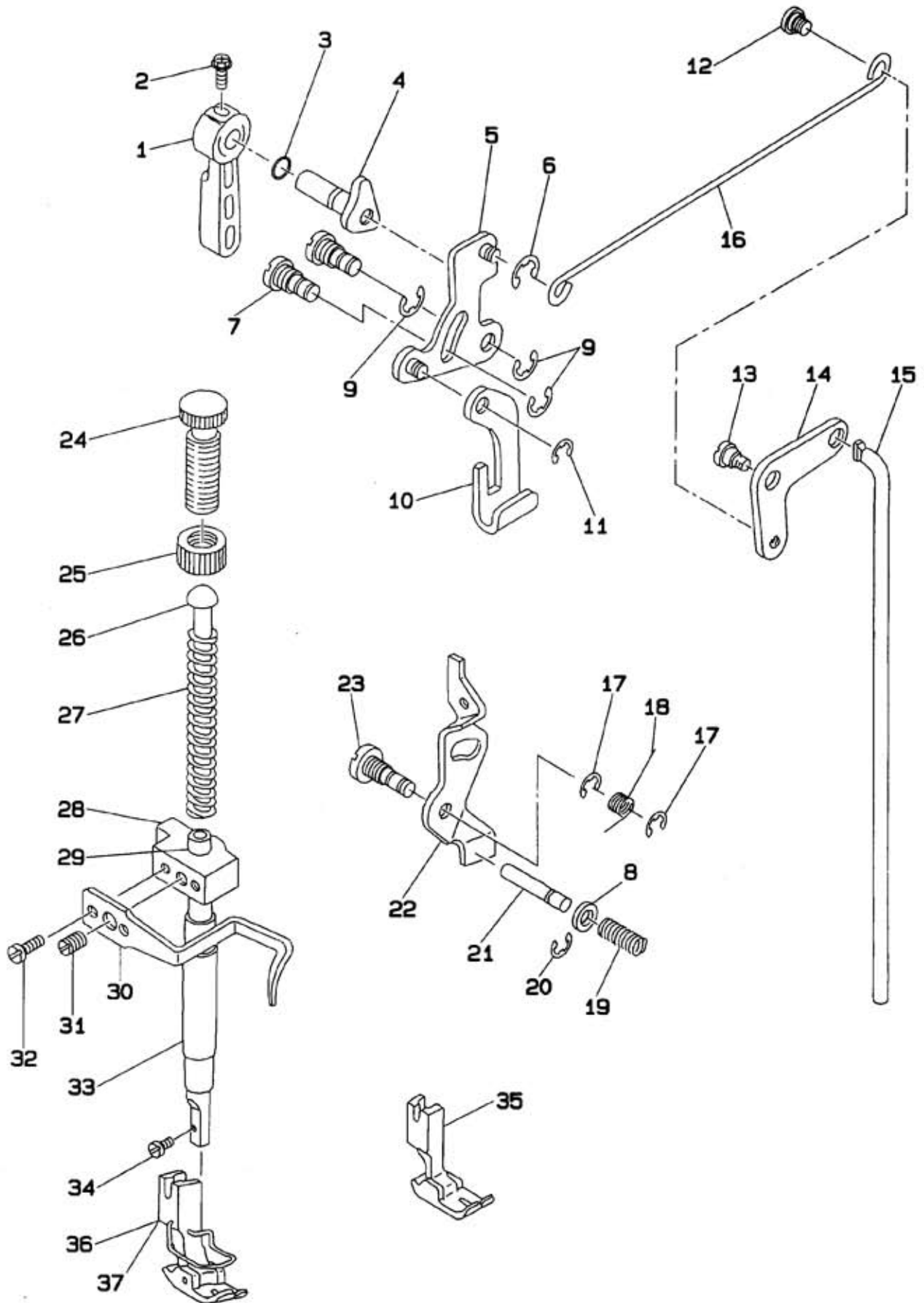

REF. NO. NOTE	PART NO.	D E S C R I P T I O N	AMT.
1	B1520 - 552 - 000 - A	HAND LIFTER	1
2	B1521 - 555 - 000	SCREW	1
3	RO - 0371801 - 00	RUBBER RING	1
4	110 - 06756	HAND LIFTER CAM ASM.	1
5	110 - 06350	HAND LIFTER LINK	1
6	RE - 0500000 - K0	SNAP RING 5	1
7	110 - 06509	LINK SHAFT	2
8	110 - 06608	GASKET	3
9	RE - 0500000 - K0	SNAP RING 5	3
10	110 - 06202	LIFTING LEVER	1
11	110 - 07309	LIFTING LEVER RING	1
12	110 - 07101	HINGE SCREW	1
13	SD - 0720332 - SP	HINGE SCREW D=7.24 H=3.3	1
14	110 - 07002	LIFTING LEVER LINK	1
15	110 - 07200	CONNECTING ROD VERTICAL	1
16	110 - 06905	LIFTING LEVER CONNECTING ROD	1
17	RE - 0500000 - K0	SNAP RING 5	2
18	110 - 18207	TENS ION RELEASE RETURN SPRING	1
19	110 - 18405	TENS ION RELEASE PIN SPRING	1
20	RE - 0400000 - K0	SNAP RING 4	1
21	110 - 18306	TENS ION RELEASE SUPPORTING PIN	1
22	110 - 18009	TENS ION RELEASE PLATE	1
23	110 - 18108	TENS ION RELEASE SHAFT	1
24	B1509 - 555 - 000	PRESSER SPRING REGULATOR	1
25	B1511 - 555 - 000	NUT 1/2 - 28	1
26	B1510 - 227 - 000	PRESSER GUIDE BAR	1
27	B1505 - 227 - 000 - A	PRESSER SPRING	1
28	110 - 06004	NEEDLE BAR GUIDE BRACKET	1
29	B1501 - 127 - 000	PRESSER BAR	1
30	110 - 06103	PRESSER BAR THREAD GUIDE	1
31	SS - 8660810 - TP	SCREW 1/4 - 40 L=8	1
32	SS - 7090910 - SP	SCREW 9/64 - 40L=8.5	2
33	B1502 - 541 - 000	PRESSER BAR BUSHING. LOWER	1
34	SS - 7091110 - SP	SCREW 9/64 - 40L=10.5	1
35	B1524 - 012 - 0B0	PRESSER FOOT ASM.	1
36	B1524 - 012 - 0A0	PRESSER FOOT ASM.	1
37	110 - 19007	WASHER PLATE	1

5. FEED MECHANISM COMPONENTS

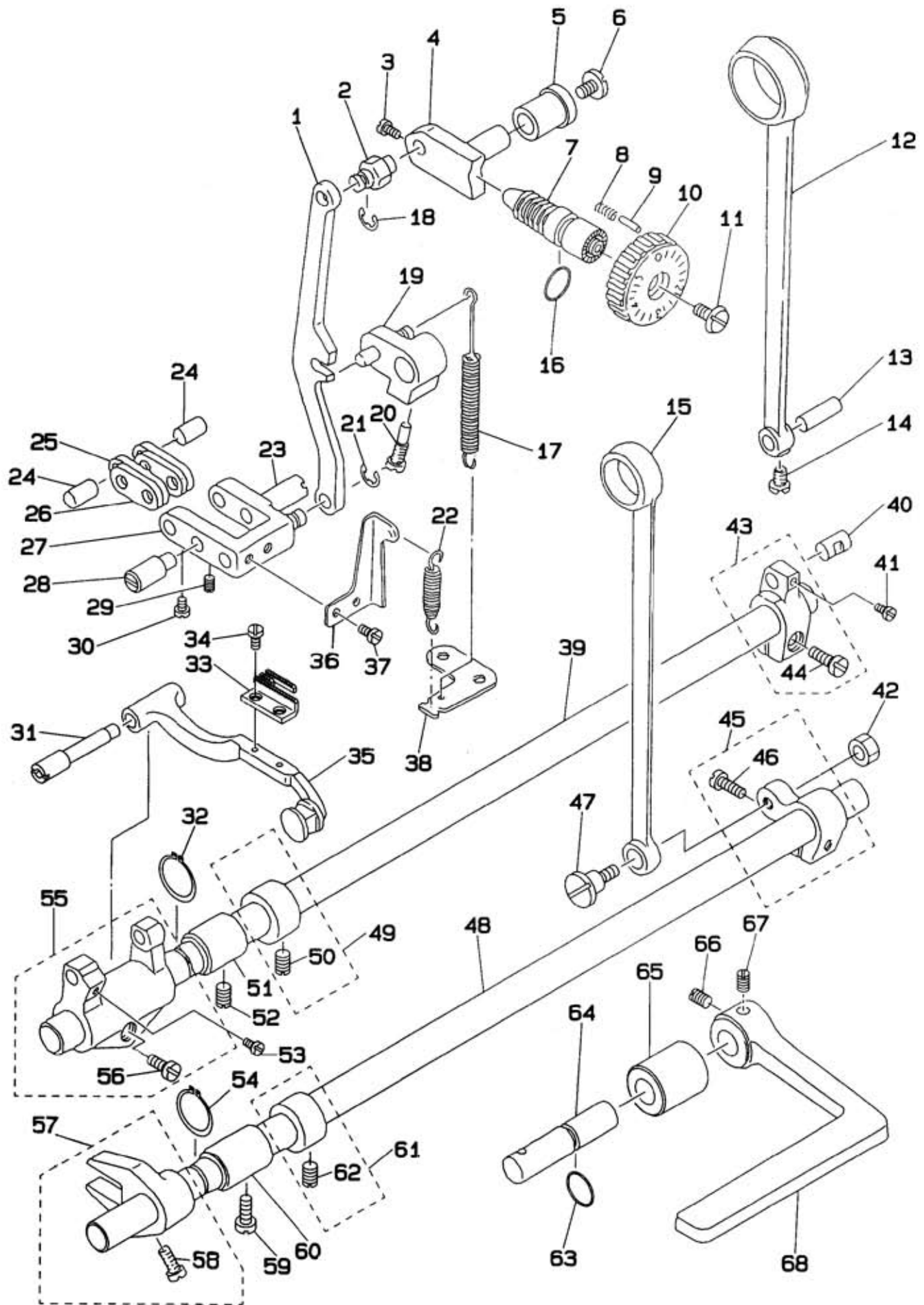

REF. NO.	NOTE	PART NO.	D E S C R I P T I O N	AMT.
1		110-09503	FEED REGULATOR CONNCTING ROD	1
2		110-09602	FEED REGULATOR PIN	1
3		SS-6090670-TP	SCREW 9/64-40 L=6	2
4		110-09701	FEED REGULATOR	1
5		110-09800	FEED REGULATOR BUSHING	1
6		SS-7120770-SH	SCREW	1
7		110-09909	FEED REGULATOR SCREW	1
8		B1148-555-000	SPRING	1
9		110-52701	PIN	1
10		110-10006	FEED DIAL	1
11		SS-6120930-TP	SCREW 3/16-28 L=9.0	1
12		110-08208	ROCKER SHAFT CONNECTING ROD	1
13		110-09206	WALKING FOOT PIN C	1
14		SS-6090620-SP	SCREW 9/64-40 L=6	1
15		110-14008	CONNECTING ROD	1
16		RO-0922702-00	RUBBER RING	1
17		110-10303	FEED REVERSE SPRING	1
18		RE-0500000-K0	SNAP RING 5	1
19		110-10154	FEED REVERSE ARM ASM.	1
20		110-10402	FEED REVERSE ARM SCREW	1
21		RE-0500000-K0	SNAP RING 5	1
22		110-09404	ADGUSTING LINK SPRING	1
23		110-08901	ADGUSTING LINK FULCRUM SHAFT B	1
24		110-09008	WALKING FOOT PIN A	2
25		110-08703	WALKING FOOT LINK	2
26		110-08604	CONNECTING LINK A	2
27		110-08455	WALKING FOOT AD JUSTING LINK	1
28		110-08802	ADGUSTING LINK FULCRUM SHAFT A	1
29		SS-8150710-SP	SCREW 15/64-28 L=7	2
30		SS-6090620-SP	SCREW 9/64-40 L=6	2
31		110-11103	FEED BAR SHAFT	1
32		RC-1381001-KP	RETAINING RING	1
33		B1613-012-A00	FEED DOG A	1
34		SS-4080620-TP	SCREW 1/8-44 L=6	2
35		110-11251	FEED BAR ASM.	1
36		110-09305	ADGUSTING LINK SPRING GUIDE	1
37		SS-7110510-SP	SCREW 11/64-40 L=5	2
38		110-11301	FEED SPRING HOOK	1
39		110-10808	FEED ROCKER SHAFT	1
40		110-09107	WALKING FOOT PIN B	1
41		SS-6090620-SP	SCREW 9/64-40 L=6	1
42		NS-6680410-SP	NUT 9/32-28	1
43		110-08356	FEED ROCKER SHAFT CRANK ASM.	1
44		SS-7121410-SP	SCREW 3/16-28 L=14	(1)
45		110-14156	REAR CRANK ASM.	1
46		SS-6121210-SP	SCREW 3/16-28 L=12	(1)
47		SD-1000801-SH	HINGE SCREW	1
48		110-14206	FEED DRIVING SHAFT	1
49		CS-147121A-SH	THRUST COLLAR ASM. D=14.72 W=12	1
50		SS-8660610-TP	SCREW 1/4-40 L=6	(2)
51		110-10907	FEED ROCKER SHAFT BUSHING	1
52		SS-8150432-TH	SCREW	1
53		SS-7110740-TP	SCREW 11/64-40 L=7	1
54		RC-1381001-KP	RETAINING RING	1
55		110-11053	FEED ROCKER ASM.	1
56		SS-7121410-SP	SCREW 3/16-28 L=14	(1)
57		110-14354	DRIVING SHAFT CRANK ASM. FRONT	1
58		SS-7111120-SP	SCREW 11/64-40 L=10.5	(1)
59		SS-4120915-SP	SCREW 12/64-28 L=9	1
60		110-10907	FEED ROCKER SHAFT BUSHING	1
61		CS-147121A-SH	THRUST COLLAR ASM. D=14.72 W=12	1
62		SS-8660610-TP	SCREW 1/4-40 L=6	(2)
63		R0-0781901-00	RUBBER PING	1
64		110-10501	FEED REVERSE SHAFT	1
65		110-10709	FEED LEVER METAL	1
66		SS-8660810-TP	SCREW 1/4-40 L=8	1
67		SS-8661040-TP	SCREW 1/4-40 L=10	1
68		110-10600	REVERSE FEED CONTROL LEVER	1

6. OIL LUBRICATION COMPONENTS

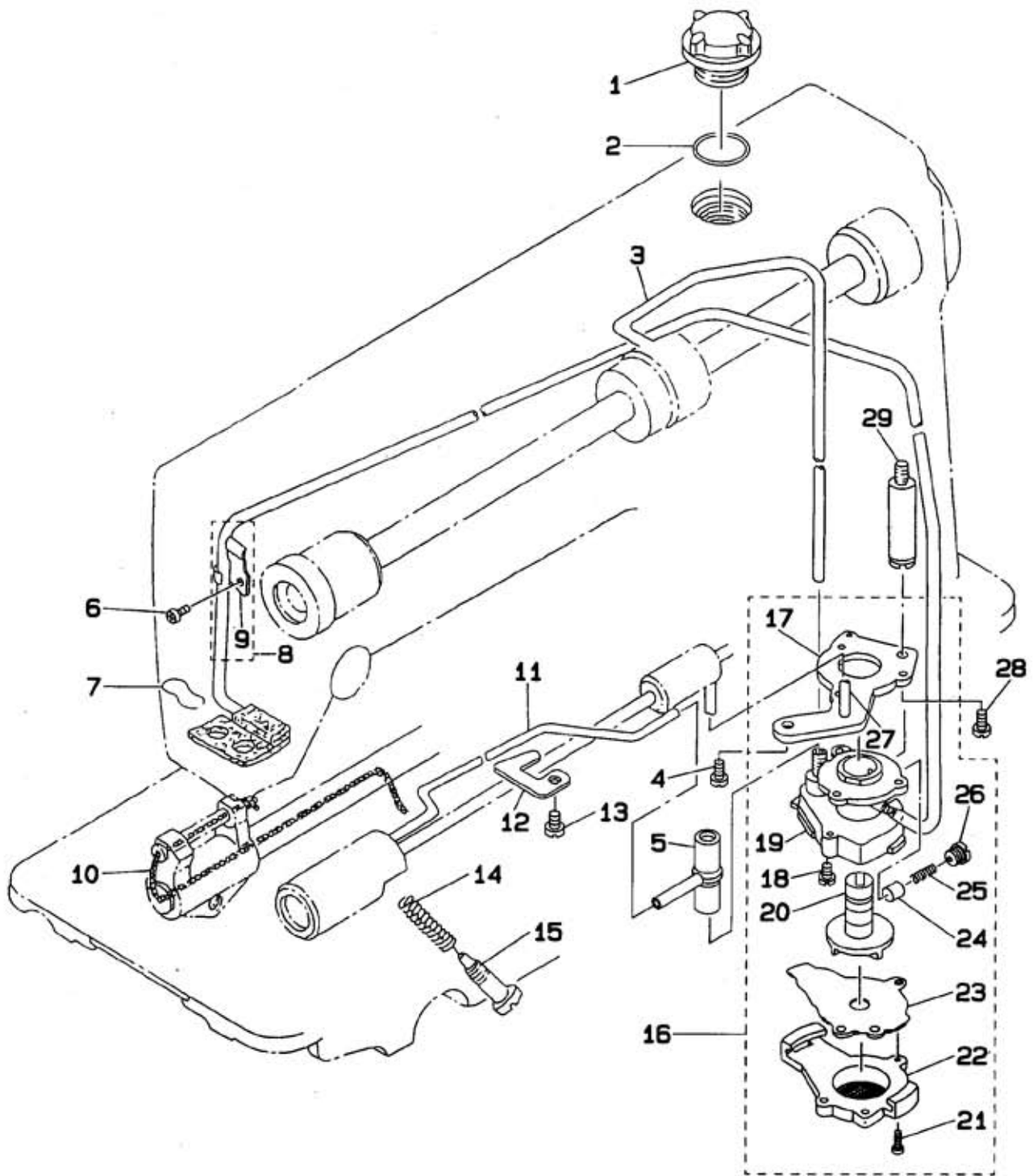

REF. NO. NOTE	PART NO.	D E S C R I P T I O N	AMT.
1	B3530 - 555 - 000	OIL SIGHT WINDOW	1
2	RO - 1952401 - 00	RUBBER RING	1
3	110 - 21201	MAIN SHAFT OIL TUBE	1
4	110 - 21607	TUBE HOLDER(UPPER)	1
5	SS - 4120615 - SP	SCREW 3/16 - 28 L=6	1
6	SS - 4120615 - SP	SCREW 3/16 - 28 L=6	1
7	B3529 - 226 - 000	OIL FELT PRESSER	1
8	110 - 21151	OIL RETURN TUBE ASM.	1
9	110 - 21805	OIL RETURN TUBE HOLDER	(1)
10	CQ - 2520000 - 00	OIL WICK	0.3
11	110 - 21300	OIL TUBE	1
12	110 - 21706	TUBE HOLDER(LOWER)	1
13	SS - 4150915 - SP	SCREW 15/64 - 28 L=9	1
14	B2616 - 372 - 000	SPRING	1
15	B3514 - 412 - 000	OIL ADJUSTING SCREW	1
16	110 - 20054	LUBRICATING OIL PUMP ASM.	1
17	110 - 20302	OIL PUMP INSTALLING BASE	(1)
18	SL - 4030851 - SF	SCREW	(3)
19	110 - 20005	OIL PUMP	(1)
20	110 - 20708	OIL PUMP IMPELLER	(1)
21	SE - 4301041 - SR	SCREW	(3)
22	110 - 20203	LUBRICATING OIL PUMP COVER	(1)
23	110 - 20807	OIL PUMP IMPELLER COVER	(1)
24	110 - 20401	PLUNGER	(1)
25	110 - 20609	PLUNGER SPRING	(1)
26	110 - 20500	PLUNGER SCREW	(1)
27	110 - 20906	HOOK DRIVING SHAFT OIL TUBE	(1)
28	SS - 6111010 - SP	SCREW 11/64 - 40 L=9.5	1
29	110 - 21003	OIL PUMP SUPPORT	1
30	SS - 4150915 - SP	SCREW 15/64 - 28 L=9	1
31	110 - 21409	RUBBER JOINT	1

7. OIL RESERVOIR COMPONENTS

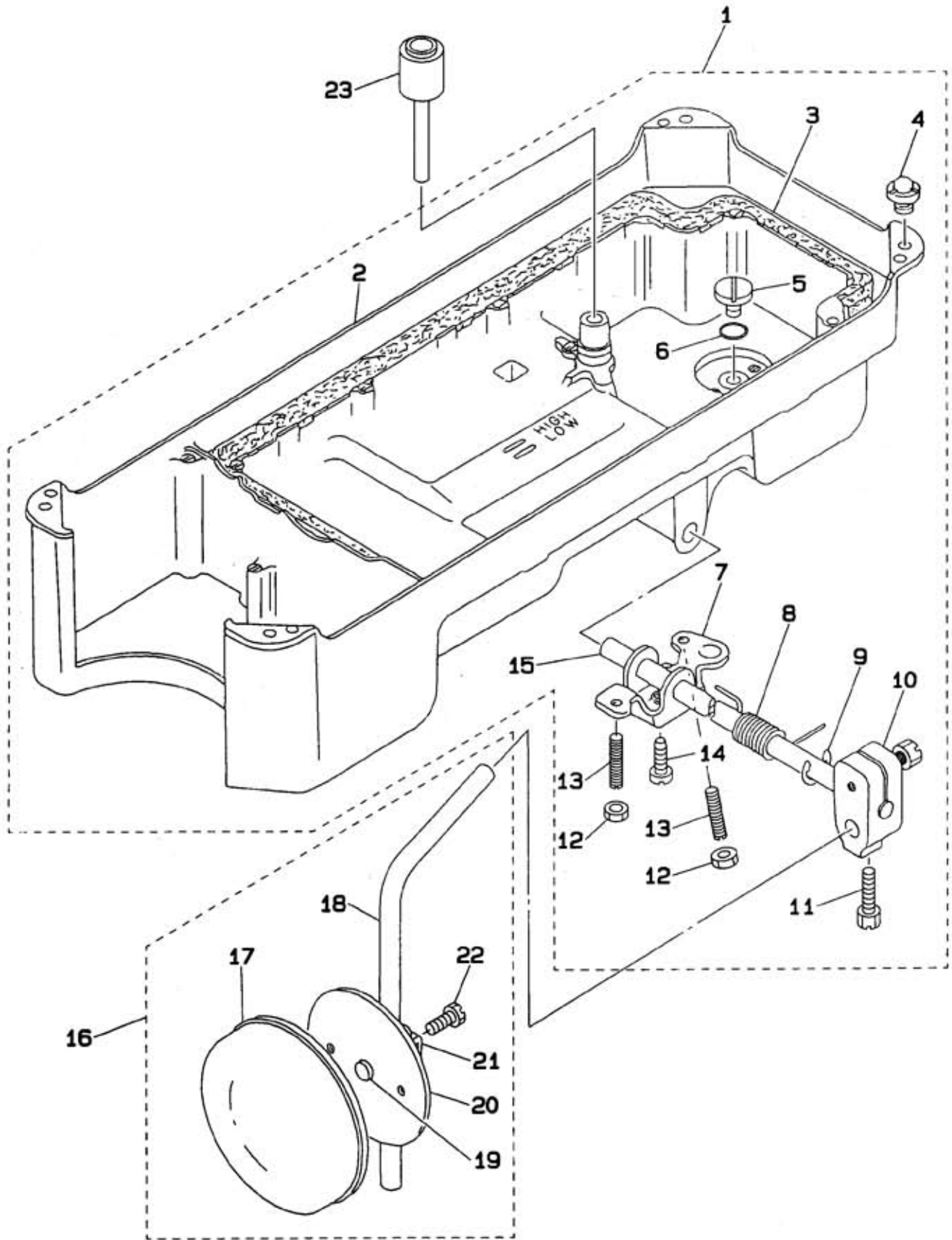

REF. NO. NOTE	PART NO.	D E S C R I P T I O N	AMT.
1	110-23058	OIL RESERVOIR ASM.	1
2	110-23009	OIL RESERVOIR	(1)
3	110-23108	GASKET	(1)
4	110-23207	RUBBER CUSHION	(4)
5	SS-6700710-SH	SCREW	(1)
6	RO-0982401-00	RUBBER RING	(1)
7	110-24007	CONNECTING ROD, VERTICAL	(1)
8	110-24106	SPRING	(1)
9	RE-1000000-K0	SNAP RING 10.0	(1)
10	110-24502	KNEE PRESS LOD BEARING BRACKET	(1)
11	SS-9182010-SN	SCREW 9/32-20 L=20	(2)
12	NS-6150430-SR	NUT 15/64-28	(2)
13	SS-8153010-SR	SCREW 15/64-28 L=30	(2)
14	SS-9151610-SR	SCREW 15/64-28 L=16	(1)
15	110-24205	KNEE PRESS ROD	(1)
16	110-23751	KNEE PRESS PLATE ASM.	1
17	B3431-552-000-A	KNEE PRESS PLATE COVER	(1)
18	B3419-122-000	KNEE LIFTER PLATE ROD	(1)
19	110-24403	RUBBER	(1)
20	110-23702	KNEE PRESS PLATE	(1)
21	110-23801	KNEE PRESS PLATE HOLDER	(1)
22	SS-9151540-SR	SCREW 15/64-28 L=15	(1)
23	110-24304	KNEE PRESS LIFTER ROD	1

8. BELT COVER & BOBBIN WINDER COMPONENTS

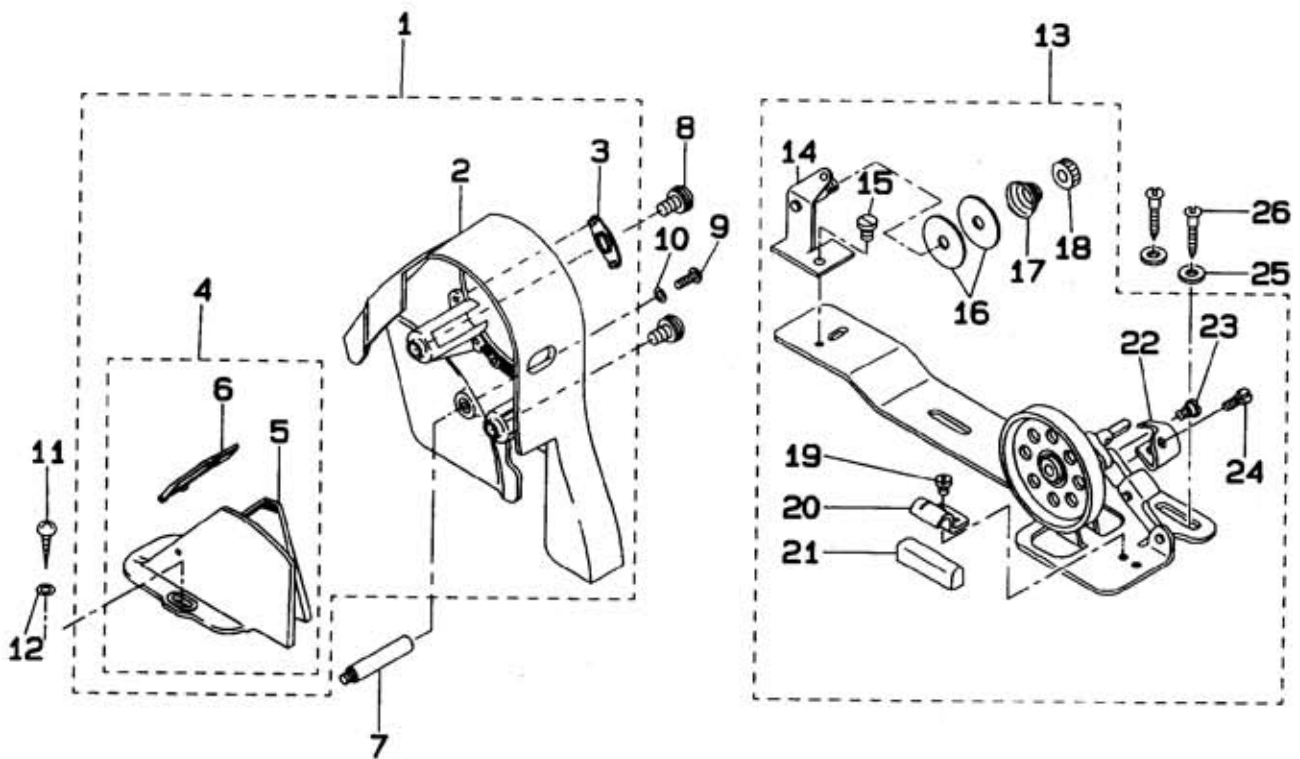

REF. NO.	NOTE	PART NO.	DESCRIPTION	AMT.
1		110-76650	BELT COVER ASM.	1
2		110-76601	BELT COVER, A	(1)
3		110-76700	BELT COVER, A CAP	(1)
4		110-76858	BELT COVER, B ASM.	(1)
5		110-76809	BELT COVER, B	(1)
6		110-76957	BELT COVER, B COVER ASM.	(1)
7		110-23504	BELT COVER SUPPORT	1
8		110-25202	BELT COVER A SCREW	2
9		SS-4121415-SP	SCREW 3/16 - 28 L=14	1
10		WP-0501016-SD	WASHER 5×10.5×1	1
11		SK-3412000-SC	WOOD SCREW D=4.1 L=20	2
12		WP-0450826-SC	WASHER 4.5×10×0.8	2
13		110-77567	BOBBIN WINDER ASM.	1
14		110-78250	THREAD TENSION ASM.	(1)
15		SS-7110840-SP	SCREW 11/64 - 40 L=7.8	(1)
16		B3126-012-000	THREAD TENSION DISK	(2)
17		B3129-012-B00	THREAD TENSION SPRING	(1)
18		110-72204	TENSION NUT	(1)
19		SS-7110350-SP	SCREW 11/64 - 40 L=3	(1)
20		110-78102	PRESSER PLATE	(1)
21		B3211-555-000	RUBBER BRAKE	(1)
22		110-78003	POSITIONING FINGER	(1)
23		SD-0490261-SP	HINGE SCREW D=4.9 H=2.6	(1)
24		SS-7081310-SP	SCREW 1/8 - 44 L=12.5	(1)
25		WP-0450826-SC	WASHER 4.5×10×0.8	2
26		SK-3412000-SC	WOOD SCREW D=4.1 L=20	2

9. THREAD STAND COMPONENTS

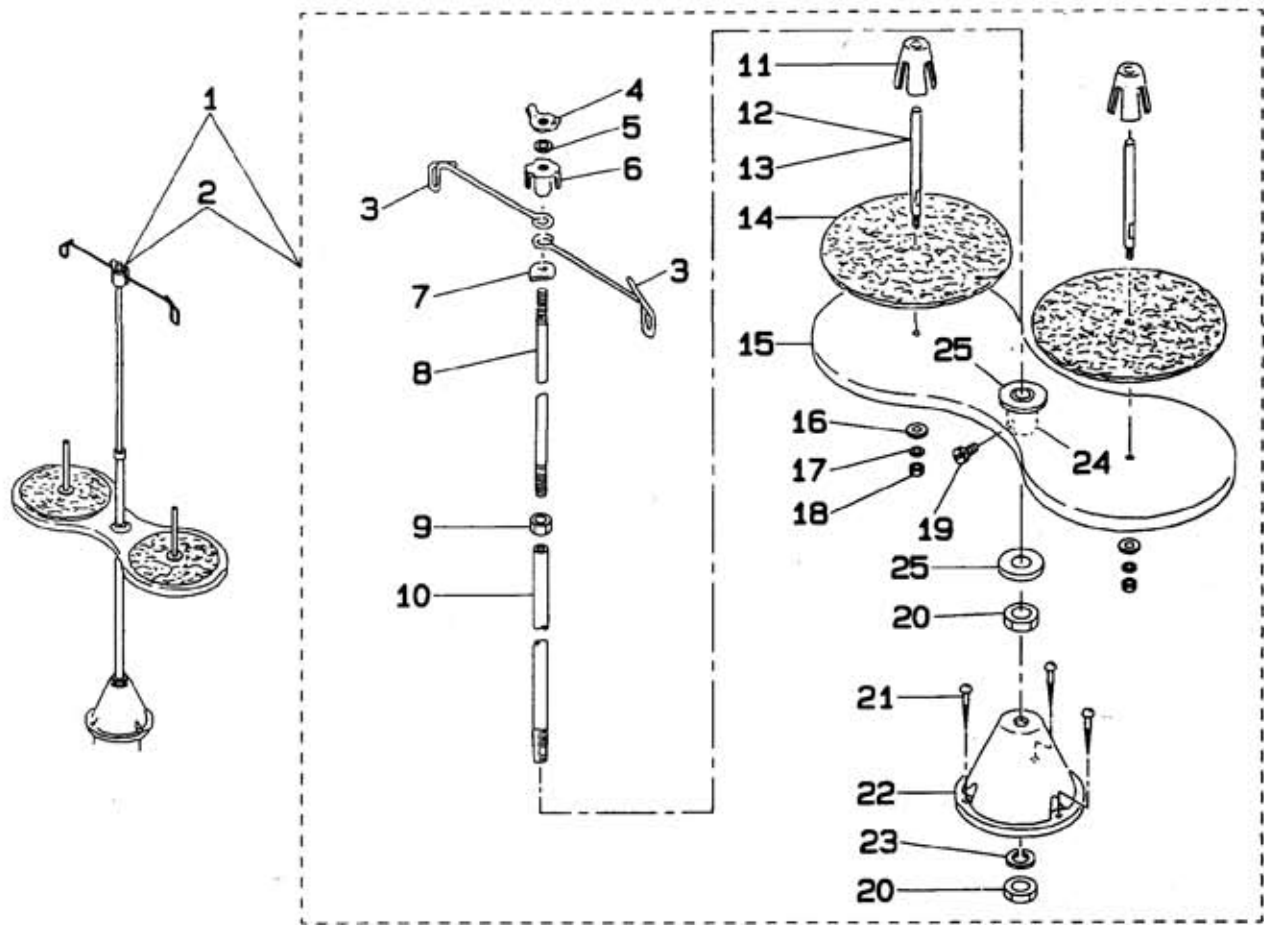

REF. NO.	NOTE	PART NO.	DESCRIPTION	AMT.
1		111-81054	THREAD STAND ASM.	1
2		111-81062	THREAD STAND ASM.	1
3		B3307-012-000	THREAD GUIDE	(2)
4		B3310-012-000	POSITION CUP SET SCREW	(1)
5		WS-0641560-KR	SPRING WASHER 6.4×11.9×1.5	(1)
6		B3309-012-000	POSITION CUP	(1)
7		B3308-012-000	ROD WASHER	(1)
8		B3306-012-000	SPOOL ROD	(1)
9		NM-6061061-SE	NUT M6	(1)
10		B3302-012-000	SPOOL REST ROD	(1)
11		111-81906	SPOOL RETAINER	(2)
12		B3320-704-L00-A	SPOOL PIN	(2)
13		B3311-012-000	SPOOL REST CUSHION	(2)
14		111-81153	SPOOL REST ASM.	(1)
15		WP-0560860-SE	WASHER 5.6×12×0.8	(2)
16		WS-3531060-KR	SPRING WASHER 5.3×8.3×1	(2)
17		NS-6123881-SE	NUT 3/16-28	(2)
18		SM-9061080-SE	SCREW M6 L=10	(1)
19		NM-6100663-SE	NUT M10	(2)
20		SK-3452000-SE	WOOD SCREW D=4.5 L=20	(3)
21		111-81005	THREAD STAND	(1)
22		WS-1002560-KR	SPRING WASHER 10×18×2.5	(1)